

Test set characterizes FET's AGC response

by John Dunn
Bertan Associates, Syosset, N. Y.

The relationship of a field-effect transistor's gate-to-source voltage (V_{gs}) to its drain-to-source resistance (R_{ds}), and consequently its suitability for use in automatic-gain-control circuits, can be found with the n-channel FET tester described here. Making the FET's R_{ds} a part of one leg of a Wien-bridge oscillator makes it possible for a technician to correlate the bridge's instantaneous output frequency with a bridge-generated voltage that corresponds to the applied V_{gs} . Because the frequency is related to R_{ds} by a simple equation, R_{ds} may be readily plotted against V_{gs} .

Operational amplifier A_1 and zener diode D_1 maintain a voltage of about 7.5 volts for the FET's source, with its uncommitted drain connected into the circuit such that under steady-state conditions the Wien bridge built around A_3 is balanced at any given frequency for:

$$R_{ds}/(R_{fb} + R_{ds}) = (j\omega C_2 C_b) / [j\omega R_a C_a (1 + j\omega R_b C_b) + (1 + j\omega R_b C_b) + j\omega C_2 C_b]$$

Because $\omega = 1/(R_a R_b C_a C_b)$, the condition for balance simplifies to:

$$R_{ds} = R_{fb} / [(R_a/R_b) + (C_b/C_a)]$$

Noting that $R_a = 1/(\omega^2 R_b C_a C_b) = 1/(4\pi^2 f^2 R_b C_a C_b)$,

V_{gs}	Frequency, Hz	R_{ds} , Ω
0	2149	17.9
-0.5	2303	20.5
-1.0	2465	23.4
-1.5	2656	27.1
-2.0	2893	32.0
-2.5	3207	39.0
-3.0	3683	50.8
-3.2	3936	57.6
-3.4	4314	68.4
-3.6	4836	84.5
-3.8	5604	110.3
-3.9	6199	131.7
-3.95	6560	145.2
-4.0	6949	160.1

where f is the frequency of the oscillator, then $R_{ds} = R_{fb} / [1/(4\pi^2 f^2 R_b^2 C_a C_b) + (C_b/C_a)]$. Thus R_{ds} may be determined for any frequency selected by R_a , and the AGC plot constructed if the corresponding V_{gs} for that frequency is recorded. Note that the required gate-to-source potential of 0 to -7.5 v is derived from the Wien bridge itself via A_2 and A_4 .

The typical response of a Motorola MPF4391 is tabulated (see table) and may be used to check the tester's operation. □

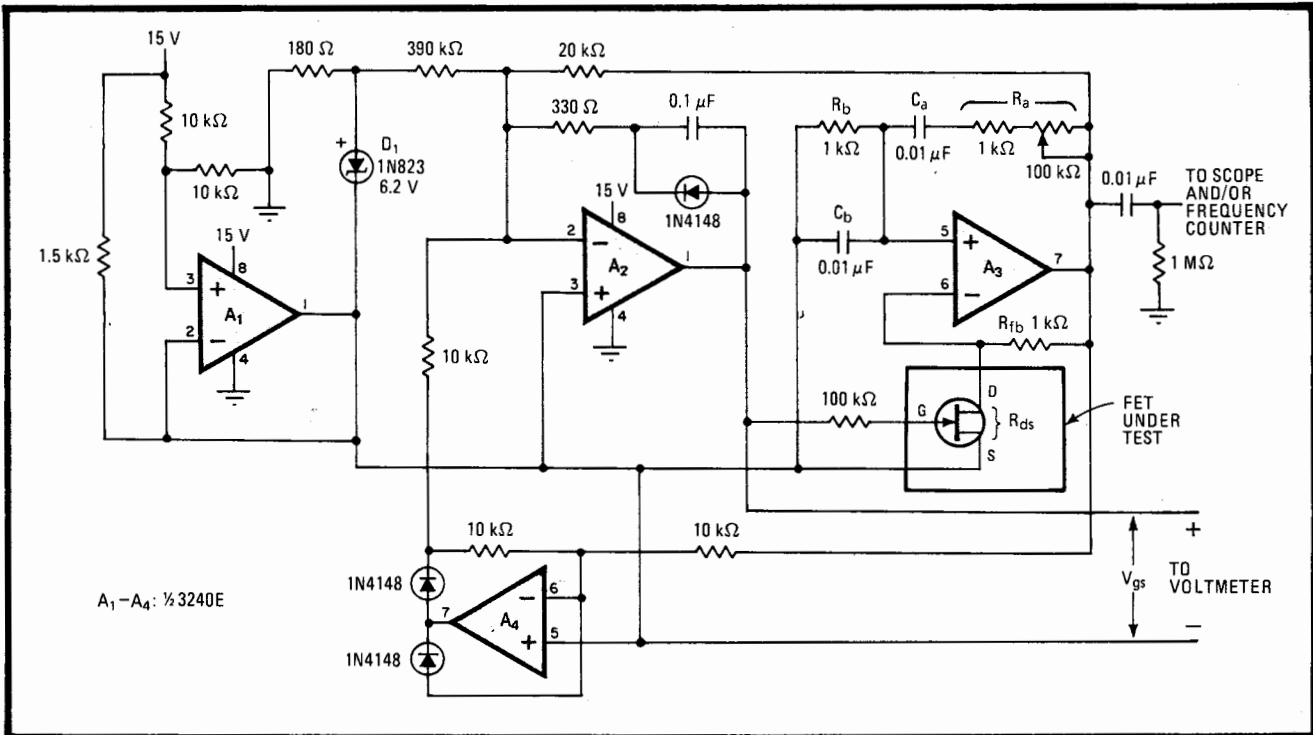

Charting gain. Tester, with n-channel FET placed in leg of Wien-bridge oscillator, helps find relationship of FET's drain-to-source resistance (R_{ds}) to its gate-to-source voltage (V_{gs}), and thus its suitability for use in automatic-gain-control circuits. The common variable is frequency, which has an effect on R_{ds} via a feedback voltage V_{gs} . The typical response of Motorola FET (table) aids in checking out the tester.