

DC Servo | 100V line systems

Description

When an amplifier clips on an asymmetrical signal (e.g. speech), one side of the signal clips harder than the other. This produces DC and will cause a lot of current to flow through the transformer primary. This will cause the over current protection to trigger which is undesired. It's a problem you get with all types of amplifier (not just class D). With the DC servo, the signal will be shifted to compensate for the clipping error.

The on-board AC coupling should be shorted out (so the amplifier becomes DC coupled). Here is a list of capacitors that need to be shorted:

UcD180V7:	C36, C37
UcD400V7:	C48, C49
UcD180OEMV3:	C17, C18
UcD400OEMV3:	C17, C18

The servo has a FET to hold the integrator in reset as long as the UcD is off. Alternative enable circuits may be used as long as this start-up order is maintained.

Application Schematic

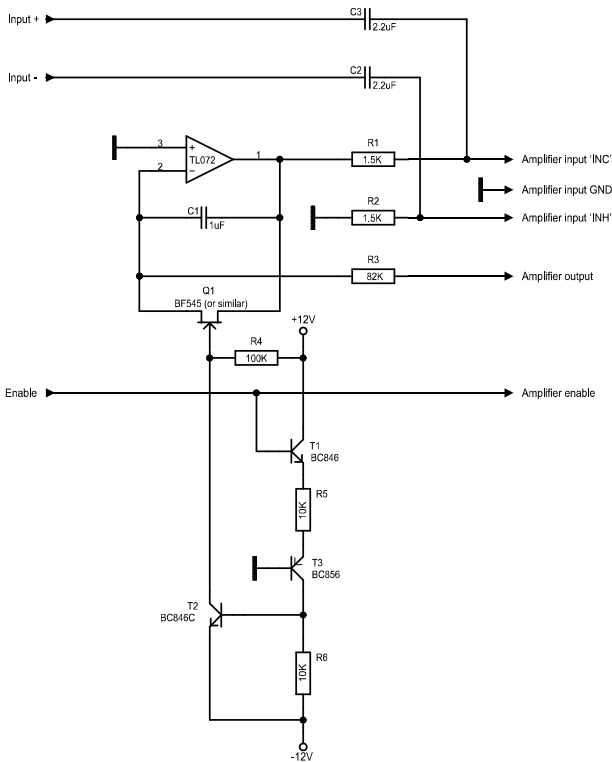

Fig.1 Typical circuit UcDxxxOEM application

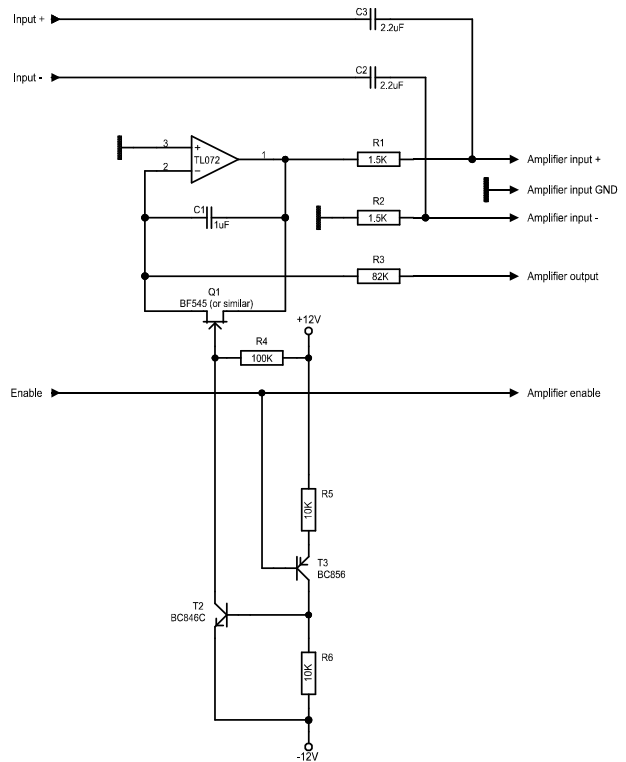

Fig.2 Typical circuit UcDxxxST application