

## ±12-V voltage sensing circuit with an isolated amplifier and differential input SAR ADC

Alex Smith

ISO224 Input Voltage	ISO Output, ADC Input ( $V_{OUTP} - V_{OUTN}$ )	Digital Output ADS7945
+12V	+4V	1999 <sub>H</sub>
-12V	-4V	E666 <sub>H</sub>

Power Supplies and Reference Voltages		
VDD1	VDD2 and AVDD	REF5050 External Ref
15V	5V	5V

### Design Description

This circuit performs a ±12-V isolated voltage sensing measurement utilizing the [ISO224](#) isolated amplifier and the [ADS7945](#) SAR ADC. The [ISO224](#) can measure true differential signals of ±12V with a fixed gain of  $\frac{1}{3}V/V$  and produces an isolated differential output voltage with an output common-mode voltage of  $VDD2 / 2$ . The [ADS7945](#) is a fully differential input ADC with a full-scale input voltage of  $\pm V_{REF}$  and a common-mode input voltage of  $V_{REF} / 2 \pm 200mV$ . Selecting a +5-V reference allows the ADS7945 to accept the full-scale and common-mode outputs from the [ISO224](#). Capturing the [ISO224](#) output with a fully differential input ADC doubles the system dynamic range compared to a single-ended conversion. Many high-voltage industrial applications such as [Protection Relays](#), [Channel-to-Channel Isolated ±10V Analog Input Cards](#), and [Inverter & Motor Control](#). The equations and explanation of component selection in this design can be customized based on system specifications and needs.

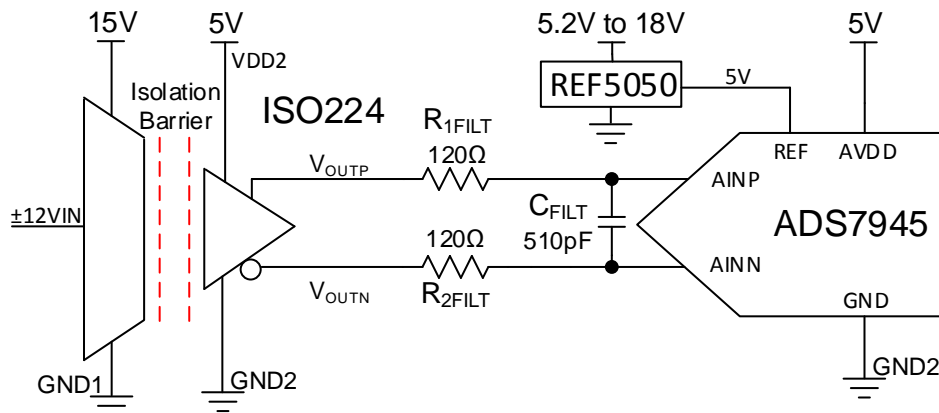

## Specifications

Specification	Calculated	Simulated
Transient ADC input settling at 100ksps	305 $\mu$ V	11 $\mu$ V
Conditioned signal range	$\pm$ 4V	$\pm$ 4V
Noise (at the input)	1.9mV <sub>RMS</sub>	1.73mV <sub>RMS</sub>
Closed-loop bandwidth	175kHz	185kHz

## Design Notes

1. The [ADS7945](#) was selected due to its low power and a compatible analog input structure with the [ISO224](#).
2. Verify the systems linear operation for the desired input signal range. This is verified using simulation in the DC Transfer Characteristics selection.
3. Select COG capacitors for C<sub>FILT</sub> to minimize distortion.
4. [Understanding and Calibrating the Offset and Gain for ADC Systems](#) covers methods for error analysis. Review the link for methods to minimize gain, offset, drift, and noise errors.
5. The [TI Precision Labs - ADCs](#) training video series covers methods for selecting the charge bucket circuit R<sub>FILT</sub> and C<sub>FILT</sub>. These component values are dependent on the amplifier bandwidth, data converter sampling rate, and data converter design. The values shown here will give good settling and AC performance for the amplifier and data converter in this example. If the design is modified, a different RC filter must be selected. Refer to [Introduction to SAR ADC Front-End Component Selection](#) for an explanation of how to select the RC filter for best settling and AC performance.

### Component Selection

1. Select an isolated amplifier based on the input voltage range and determine the output common-mode voltage and output voltage range:

#### ISO224:

- $\pm 12$ -V single-ended input range
- Fixed gain of  $\frac{1}{3}$ , yielding  $\pm 4$ -V differential output
- Output common-mode voltage of +2.5V
- 4.5-V to 18-V high-side power supply, 4.5-V to 5.5-V low-side power supply
- Input Offset:  $\pm 5$ mV at 25°C,  $\pm 42$  $\mu$ V/°C maximum
- Gain Error:  $\pm 0.3\%$  at 25°C,  $\pm 50$ ppm/°C maximum
- Nonlinearity:  $\pm 0.01\%$  max,  $\pm 1$ ppm/°C
- High-input impedance of 1.25M $\Omega$

2. Select an ADC with an appropriate common-mode and differential input range to pair with the +2.5-V common-mode and  $\pm 4$ -V differential output of the ISO224:

#### ADS7945:

- $\pm 5$ -V maximum analog input range
- Full-scale input span set by  $\pm$ voltage reference
- Input common-mode range of  $V_{REF} / 2 \pm 0.2$ V
- 2.7-V to 5.25-V power supply
- High SNR of 84, low power of 11.6mW at 2Msps

3. Select a voltage reference that supports the common-mode constraint set by the 2.5-V common-mode output of the ISO224 and the  $V_{REF} / 2 \pm 0.2$ -V common-mode input voltage of the ADS7945. This means that the reference output voltage must be 5V, low noise, and a configurable input voltage is preferred:

#### REF5050:

- 5-V output
- 5.2-V to 18-V input voltage power supply
- 3 $\mu$ VPP/V noise

4. Select  $R_{1FILT}$ ,  $R_{2FILT}$ , and  $C_{FILT}$  for settling of the input signal and sample rate of 100ksps:

*Refine the  $R_{FILT}$  and  $C_{FILT}$  Values* is a TI Precision Labs video showing the methodology for selecting  $R_{FILT}$  and  $C_{FILT}$ . The final value of 120 $\Omega$  and 510pF proved to settle to well below  $\frac{1}{2}$  of a least significant bit (LSB) within the acquisition window.

### DC Transfer Characteristics

The following graph shows the simulated output for a  $\pm 15\text{-V}$  input. The desired linear range is a  $\pm 4\text{-V}$  output for a  $\pm 12\text{-V}$  input. This simulation shows that the linear output range is approximately  $\pm 4.6\text{V}$  which is well beyond the requirement.

The transfer function shows the ISO224 gain is  $\frac{1}{3}$  (that is,  $\text{Gain} \cdot V_{\text{IN}} = V_{\text{OUT}}$ ,  $(\frac{1}{3}) \cdot (12\text{V}) = 4\text{V}$ ).

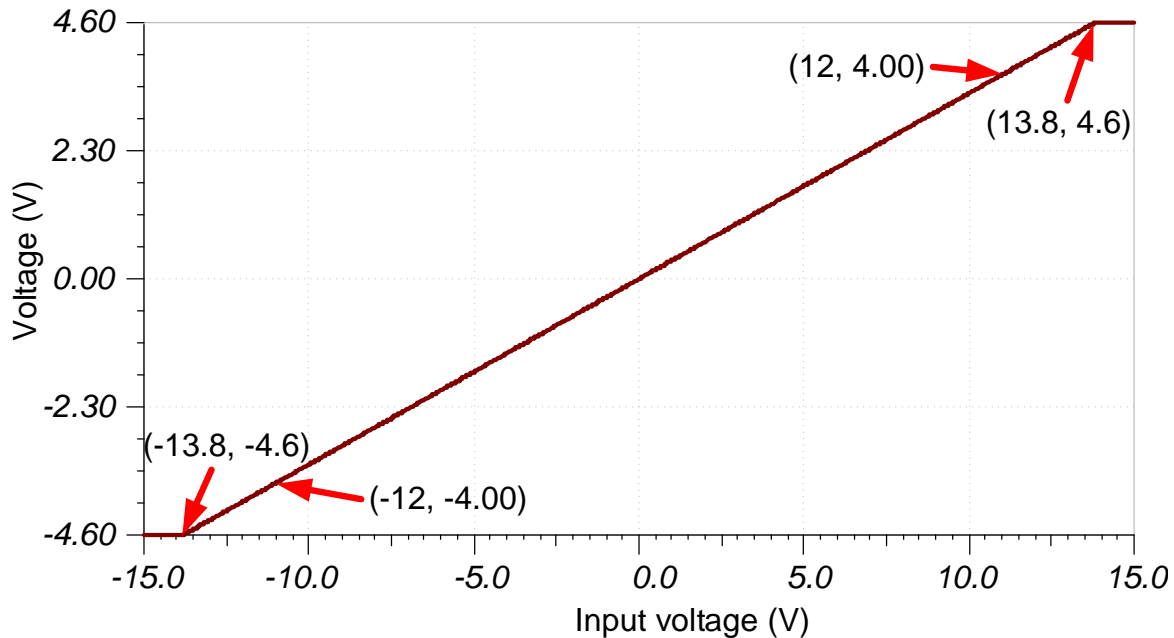

### AC Transfer Characteristics

The simulated bandwidth is approximately 186kHz and the gain is  $-9.57\text{dB}$  (or  $0.332\text{V/V}$ ) which closely matches the expected gain and bandwidth for the ISO224 (specified  $f_c = 175\text{kHz}$ , gain =  $0.333\text{V/V}$ ).

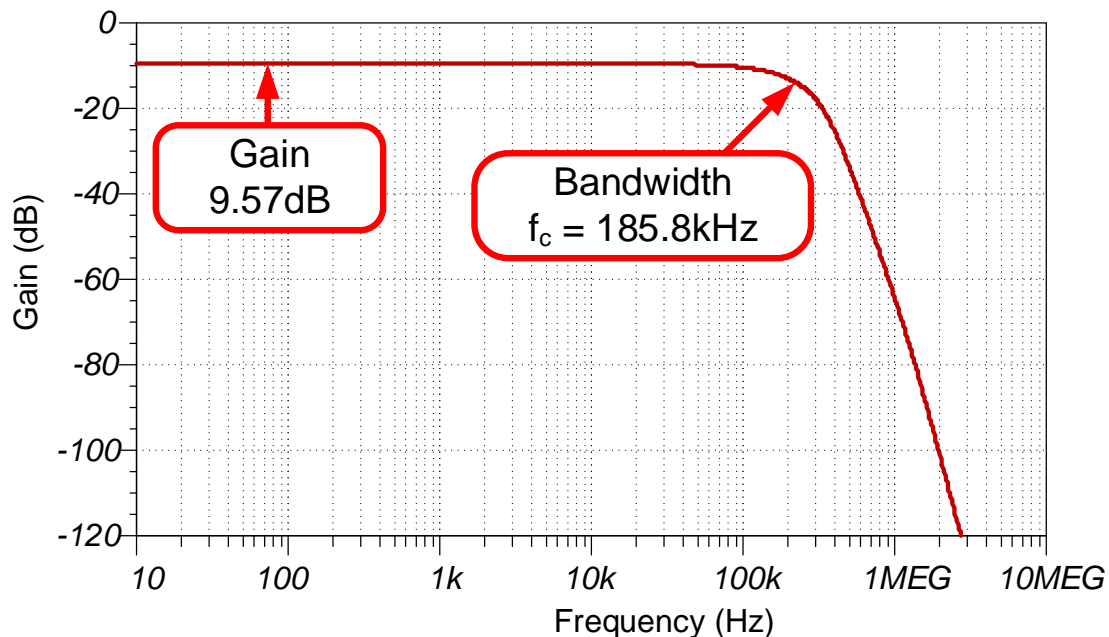

### Transient ADC Input Settling Simulation

The following simulation shows the transient settling results with an acquisition time of  $9.6\mu\text{s}$ . The  $11\text{-}\mu\text{V}$  settling error is well within the  $0.5 * \text{LSB}$  limit of  $305\mu\text{V}$ . See [Refine the Rfilt and Cfilt Values](#) for detailed theory on this subject.

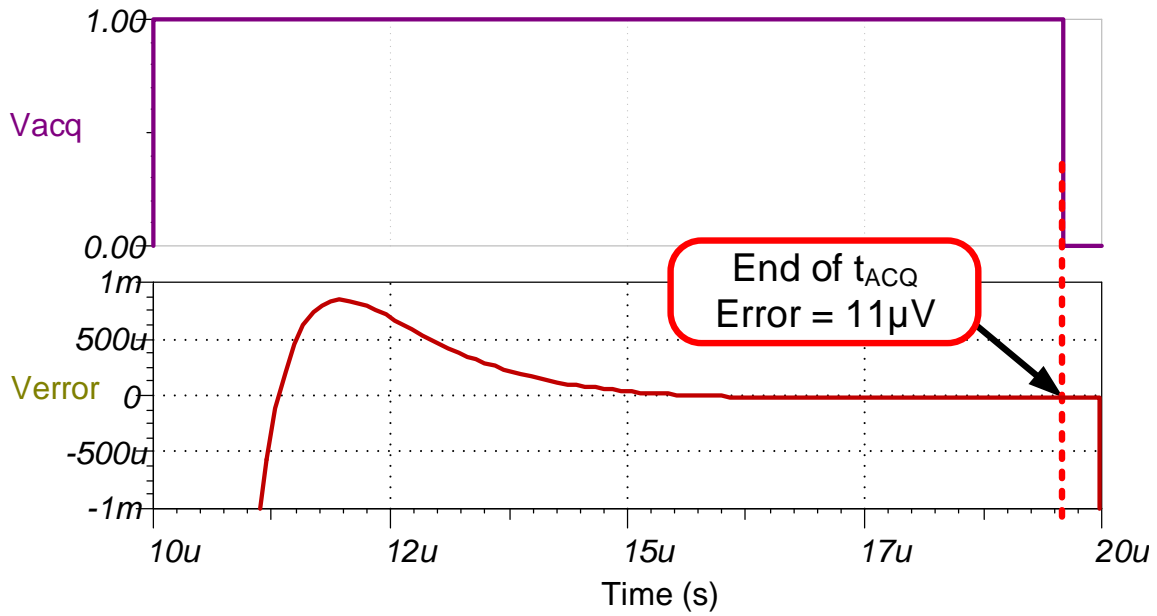

## Noise Simulation

The following noise calculation looks only at the noise of the [ISO224](#). The [ISO224](#) noise is substantially higher than other noise sources in the circuit, so the total noise can be approximated as the [ISO224](#) noise. The same method can be used for the B grade.

$$E_{nISO224A} = Gain(e_n)\sqrt{1.57 \cdot BW}$$

$$E_{nISO224A} = \frac{1}{3} (4\mu V / \sqrt{Hz}) \sqrt{1.57 \cdot 176kHz} = 0.7mV_{RMS}$$

The simulated noise is greater than the expected calculated noise. This difference is due to noise peaking in the simulation model. The noise peaking is not included in the calculation. Refer to [Calculating the Total Noise for ADC Systems](#) for detailed theory on this subject.

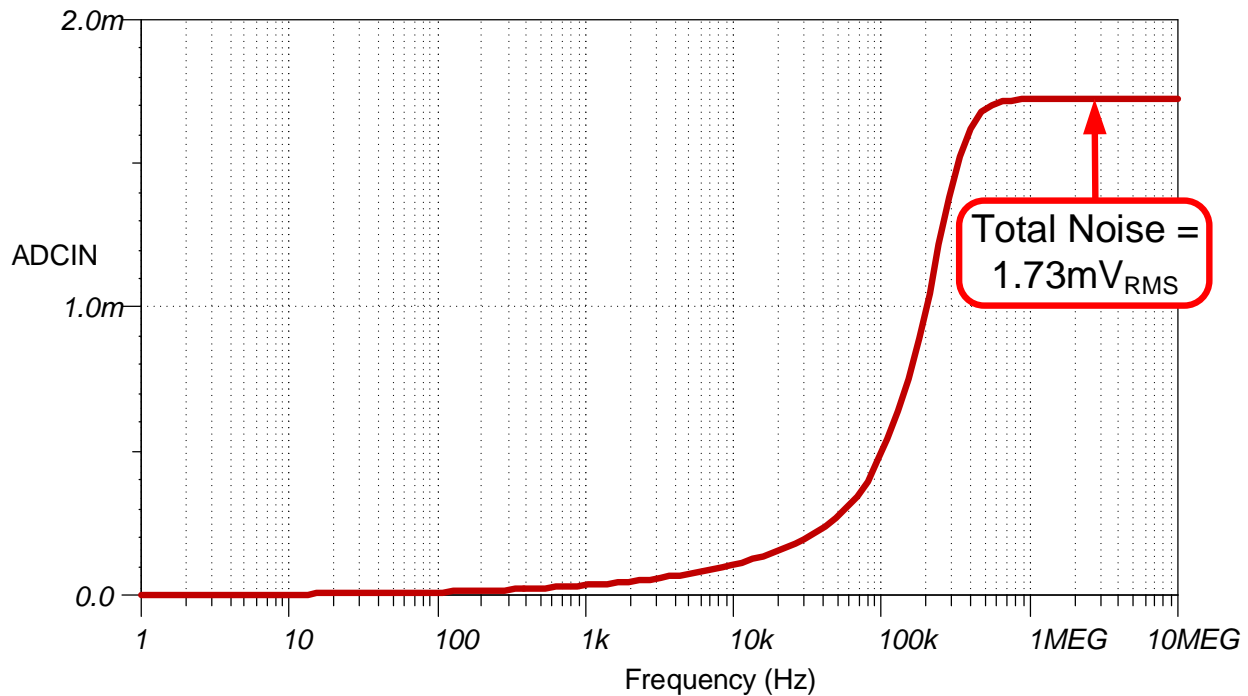

## Design Featured Devices

Device	Key Features	Link	Similar Devices
ISO224	±12-V single-ended input range, Fixed gain of 1/2, yielding ±4-V differential output, output common-mode voltage of +2.5V, 4.5-V to 18-V high-side power supply, 4.5-V to 5.5-V low side power supply, input offset: ±5mV at 25°C, ±42μV/°C max, gain error: ±0.3% at 25°C, ±50ppm/°C maximum, nonlinearity: ±0.01% maximum, ±1ppm/°C, high-input impedance of 1.25MΩ	<a href="http://www.ti.com/product/ISO224">www.ti.com/product/ISO224</a>	<a href="http://www.ti.com/isoamps">www.ti.com/isoamps</a>
ADS7945	±5 V max analog input range, full-scale input span set by ±voltage reference, input common mode range of $V_{REF} / 2 \pm 0.2V$ , 2.7-V to 5.25-V power supply, high SNR of 84, low power of 11.6mW at 2Msps	<a href="http://www.ti.com/product/ADS7945">www.ti.com/product/ADS7945</a>	<a href="http://www.ti.com/opamps">http://www.ti.com/opamps</a>
REF5050	3ppm/°C drift, 0.05% initial accuracy, 4μVpp/V noise	<a href="http://www.ti.com/product/REF5050">www.ti.com/product/REF5050</a>	<a href="http://www.ti.com/vref">http://www.ti.com/vref</a>

### Design References

See [Analog Engineer's Circuit Cookbooks](#) for TI's comprehensive circuit library.

### Link to Key Files

See the TINA files for Isolated Design - <http://www.ti.com/lit/zip/sbac213>.