

The right way to use instrumentation amplifiers

AVOID COMMON APPLICATION PROBLEMS WHEN CONNECTING REAL-WORLD SIGNALS TO INSTRUMENTATION AMPLIFIERS.

Instrumentation amplifiers find wide use in real-world data acquisition. However, designers often incorrectly apply them. Specifically, although modern in amps have excellent CMR (common-mode rejection), designers must limit the total common-mode voltage, plus the signal voltage, to avoid saturating the amplifier's internal input buffers. Unfortunately, they often overlook this requirement.

Other common application problems result from driving the in-amp reference terminal with a high-impedance source, operating low-supply-voltage in-amp circuits at gains that are much too high, ac coupling in-amp inputs without providing a dc return path to ground, and using mismatched RC-input-coupling components.

A QUICK IN-AMP PRIMER

An in amp is a closed-loop-gain block with a differential input and a single-ended output. In amps also typically have a reference input that allows the user to level-shift the output voltage up or down. You use one or more internal or external resistors to set gain.

Figure 1 shows a bridge-preamplifier circuit, a typical in-amp application. When sensing a signal, the bridge-resistor values change, unbalancing the bridge and causing a change in differential voltage across it. The signal output is this differential voltage, which connects directly to the in amp's inputs. In addition, under zero-signal conditions, a constant dc voltage is also present on both lines. This dc voltage is the same, or common mode, on both input lines.

In its primary function, the in amp normally rejects the common-mode dc voltage or any other voltage common to both lines, such as noise and hum, and amplifies the differential-signal voltage, the difference in voltage between the two lines.

CMR: OP AMP VERSUS IN AMP

For many applications, CMR is essential for extracting weak signals in the presence of noise, hum, or dc-offset voltages. Op amps and in amps both provide some CMR. However, in amps prevent the common-mode signal from appearing at the amplifier output. Even though the op amp also has CMR, the common-mode voltage normally transfers to the output, at unity gain, along with the signal.

Figure 2 shows an op amp connected to an input source (a bridge sensor). The bridge output is riding on a common-mode dc voltage. Because of feedback applied externally between the op amp's output and its summing junction, the voltage on the + input is the same as that on the - input. Therefore, the op amp ideally has 0V across its input terminals. As a result, the voltage at the op-amp output must equal V_{CM} , for 0V differential input.

In practice, the op amp's closed-loop gain amplifies the signal, and the common-mode voltage receives only unity gain. This difference in gain does provide some reduction in common-mode voltage, as a percentage of signal voltage. However, the common-mode voltage still appears at the output, and its presence reduces the amplifier's available output swing. For many reasons, any common-mode dc or ac signal appearing at the op amp's output is highly undesirable.

Figure 3 shows the common three-op-amp in-amp circuit. A modern IC instrumentation amplifier, such as Analog Devices' AD8221, normally includes all of these components. As with an op amp, the input buffers of an in-amp circuit, A_1 and A_2 , amplify the signal voltage, and the common-mode voltage receives only unity gain. But now, each buffer's output drives a

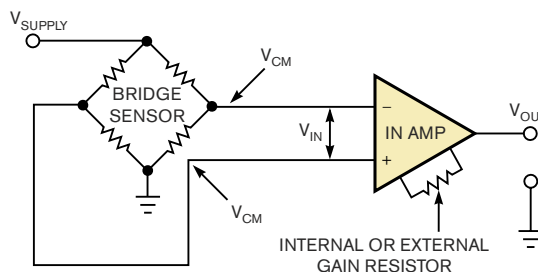
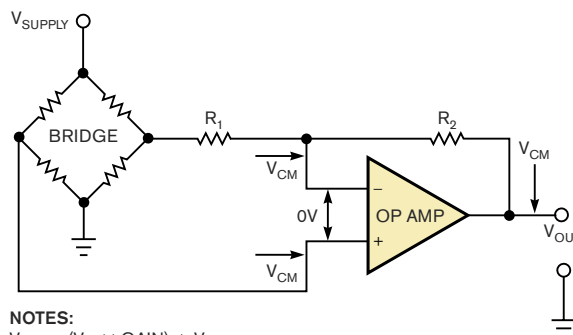

Figure 1 Designers can use instrumentation amplifiers in classic bridge circuits. Here, the dc common-mode voltage can easily be a large percentage of the supply voltage.



NOTES:
 $V_{OUT} = (V_{IN} \times GAIN) \pm V_{CM}$
 CM GAIN = 1.

Figure 2 This inverting amplifier circuit uses an op amp. Here, both the signal voltage and the common-mode voltage appear at the amplifier's output.

subtractor circuit, A_3 , which passes only the difference voltage and effectively rejects any common-mode voltages.

A common application problem that affects monolithic devices of the three-op-amp in-amp configuration occurs when dc common-mode input voltages render a single-supply in-amp circuit inoperative. Designers often correctly select a so-called single-supply in amp, so that they can operate the circuit from a low, single-supply voltage. But then they run into trouble.

For example, take the case of an in-amp bridge circuit operated from a 5V-dc single-supply voltage (Figure 4). Many designers simply ground the in amp's reference-input terminal, V_{REF} , as they normally would for dual-supply operation.

In this simplified case, with a bridge circuit using equal-value resistors, the buffers' (zero-signal) outputs (A_1 and A_2) are both 2.5V dc. This situation occurs because the in amp's buffers operate at unity gain for common-mode voltages. With both buffers applying the same 2.5V dc to the in amp's output-subtractor section, it tries to swing to 0V. In reality, even good "rail-to-rail" amplifiers cannot swing all the way down to the negative supply—in this case, "ground" or 0V—so a fairly large error already exists. Clearly, any signals from the bridge that would otherwise try to swing the in-amp output negative make no change at all. So, the circuit is basically nonfunctional, and an unwary designer may easily not notice this problem because the in amp's output appears to be about the same as it would be with no common-mode voltage applied.

A solution to this common problem is to apply half the supply voltage, 2.5V, to the in amp's reference pin, so that A_3 's output is centered at midsupply. The output can now swing both above and below this mid-supply voltage. However, other things being equal, low-voltage, single-supply circuits typically have less dynamic range than their dual-supply cousins.

A similar problem occurs when low supply voltages and high amplifier gain render the in-amp circuit inoperative. It most commonly occurs when in amps are operating at high gains, such as 1000 (Figure 5). Under these circumstances, a 10-mV-p-p input times a gain of 1000 creates a 10V-p-p signal between the outputs of A_1 and A_2 . When using $\pm 15V$ supplies, this situation may be possible. However, the in amp will become nonfunctional if a 5V single or even a 5V dual supply powers the circuit. And, if the circuit is a bridge amplifier with its inherently high dc common-mode voltage, it adds further complications.

Because users of monolithic ICs do not have access to the buffer outputs, A_1 and A_2 , they see what's happening only at the final output—the output of A_3 . Again, this situation may result in a serious design problem that goes undetected, sometimes

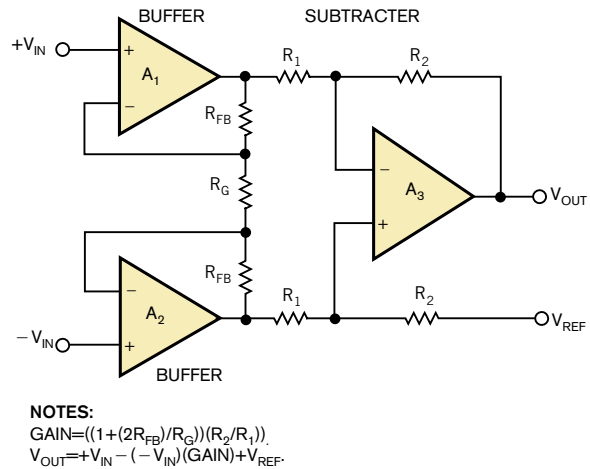

Figure 3 A common instrumentation amplifier employs three op amps.

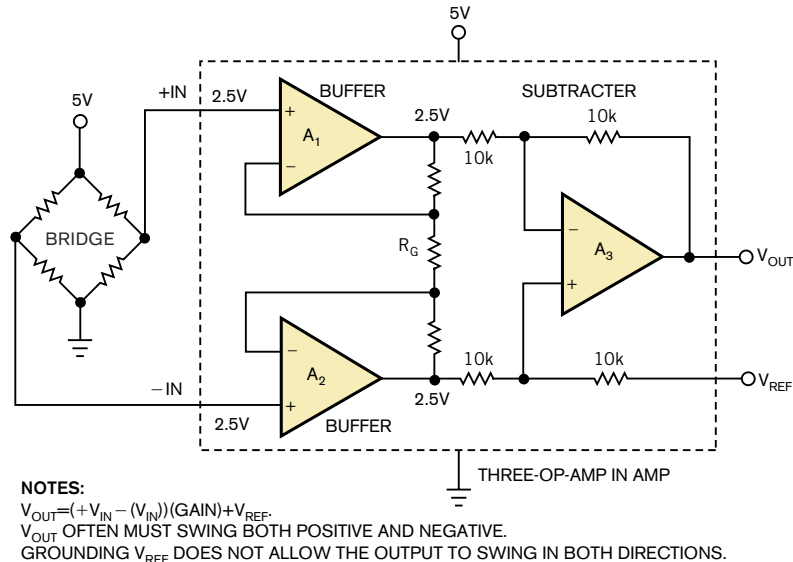

Figure 4 A three-op-amp in-amp circuit may exhibit a reduced common-mode-voltage range.

TABLE 1 RECOMMENDED COMPONENT VALUES FOR AC COUPLING IN-AMP INPUTS

-3-dB low frequency roll-off (Hz)	RC-coupling components		Input-bias current I_B (nA)	V_{OS} (ΔV_{CM}) at each input	V_{OS} error for 2% R_1, R_2 mismatch, assuming $I_{B1} = I_{B2}$ (μA)
	C_1, C_2 (μF)	R_1, R_2 (Ω)			
2	0.1	1M	2	2 mV	40
2	0.1	1M	10	10 mV	200
30	0.047	115k	2	230 μV	5
30	0.1	53.6k	10	536 μV	11
100	0.01	162k	2	324 μV	7
100	0.01	162k	10	1.6 mV	32
500	0.002	162k	2	324 μV	7
500	0.002	162k	10	1.6 mV	32

until the product is out in the field.

Another common application problem stems from operating standard, non-rail-to-rail devices, from low single-supply voltages. A high-quality rail-to-rail in amp, such as Analog Devices' AD623, can swing its output to within 0.5V of the positive-supply line and down to 0.01V above ground. Its input-voltage range is similar. Under these conditions, the amplifier's output swing almost equals the supply voltage. So, when using a 5V single supply, the amplifier has approximately a 4.49V output swing. Unfortunately, some designers forget about amplifier headroom and use standard, non-rail-to-rail products in these applications. Even a good dual-supply in amp has an output swing within only about 2V of either rail. So, using a 12V single-supply voltage, with the in amp's output centered on 6V, a rail-to-rail amplifier could swing $\pm 5.5V$, but a standard product would have only $\pm 4V$ output swing (11V p-p versus 8V p-p).

Yet another common application problem occurs when designers try to drive the reference pin of an in amp with a high-impedance source. Typical values for the impedance of the reference input in many popular in amps are 20 to 125 k Ω . If a low-impedance source, such as an op amp, is directly driving the reference, there is no problem. But often, an unwary designer tries to use a resistive voltage divider as a low-cost ratio-metric reference and ends up introducing serious errors (Figure 6).

The reference input is part of the output-subtractor circuit in a typical three-op-amp instrumentation amplifier. As such, it has a finite input resistance, approximately equal to R_{REF1} plus R_{REF2} —usually, $2 \times R_{REF}$. Adding external resistor R_2 between the reference terminal and common unbalances the A_3 subtractor circuit, introducing a CMR error. An obvious way to minimize this problem is to reduce the value of R_2 to approximately 0.1% of R_{REF1} plus R_{REF2} (for 60-dB CMR). However, with 10-k Ω values of R_{REF1} and R_{REF2} (20,000 total input Z), R_2 needs to be 20 Ω . This value, in turn, unnecessarily burns large amounts of supply current in the voltage-divider network. There is also the issue of R_{REF1} and R_{REF2} 's shunting R_2 and causing a reference-voltage error.

Together, these errors present a strong case for the use of an op-amp buffer to drive the reference pin (Figure 7). The op amp has a low output impedance—typically less than 1 Ω —and consequently does not contribute any significant CMR error. Note that using two 1% resistors in this application can produce as much as 2% gain error due to resistor mismatch.

Limits on dc CMR and the fact that many circuits do not require a true dc response tempt designers to ac couple the inputs of in-amp circuits. A common, incorrect procedure is to simply connect a suitable capacitor in series with each in-amp input terminal (Figure 8).

Again, because a monolithic in amp is a complete package, designers often fail to realize what is inside the IC. In amps thus connected with these "floating" inputs have no dc reference. The input bias currents charge up the ac coupling capacitors, C_1 and C_2 , until they exceed the input common-mode voltage.

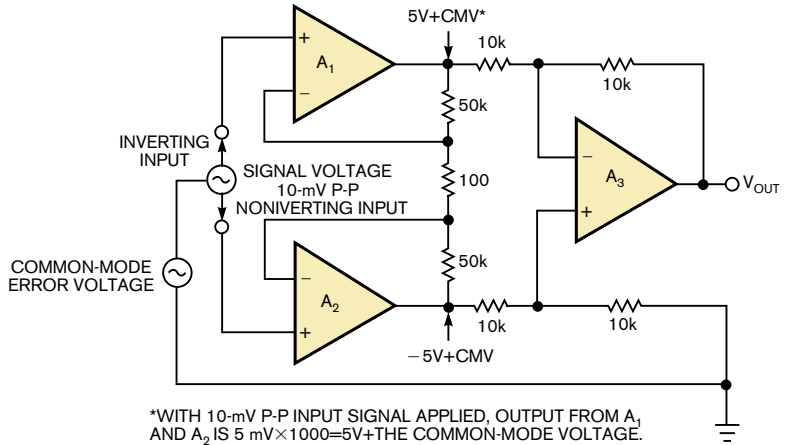

Figure 5 High gain and low supply voltages can result in buffer-amplifier clipping.

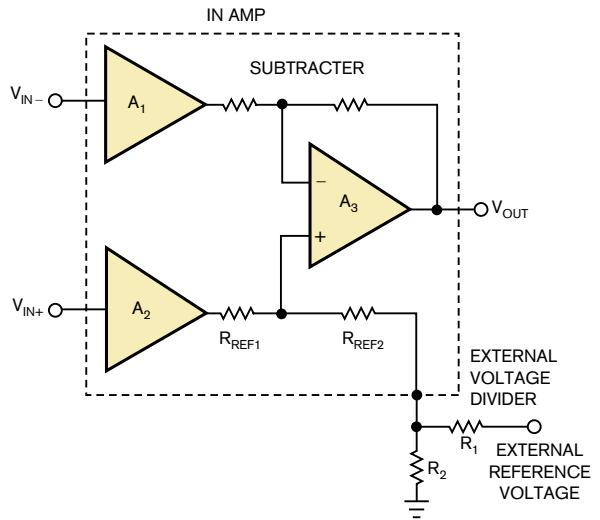

Figure 6 Driving the reference input from a high-Z source can introduce errors. In this case, R_2 's resistance causes a CMR error as R_{REF1} and R_{REF2} are now unbalanced. The shunting of R_2 by R_{REF1} and R_{REF2} introduces an additional voltage-reference error.

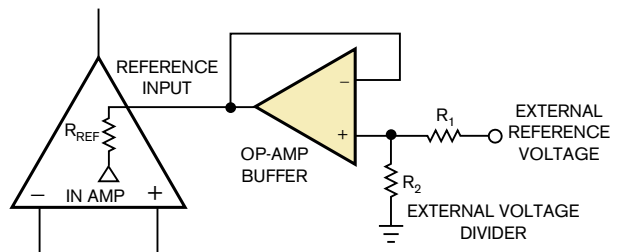

Figure 7 Adding an op-amp buffer amplifier isolates the in amp's reference terminal from the voltage divider.

In other words, the capacitors charge up to the supply line or down to ground, depending on the direction of the input bias currents. With a FET input device and high-value capacitors, it could take several minutes before the in amp becomes inoperative. Therefore, a casual lab test might not detect this problem, so it's important to avoid it altogether. Fortunately, for dual-supply operation, a simple solution exists: Just add two large-value dc return resistors, one between each input and ground (Figure 9). Now, both inputs are dc-referenced to ground and move only when an input signal drives them.

Using an in amp powered by a single supply, ac coupling is more complicated and normally requires applying a dc common-mode voltage, V_{CM} , to both inputs (Figure 10). This step is necessary, because the in amp's output cannot swing below the negative supply—in this case, ground. Here, if the in amp's output voltage tries to swing more than a few millivolts negative, the signal is clipped.

MORE AT EDN.COM

Go to www.edn.com/ms4143 and click on Feedback Loop to post a comment on this article.

Choosing appropriate voltages for V_{CM} and V_{REF} is the next important design consideration, especially in low-supply-voltage applications. In general, set V_{CM} to the middle of the expected input dynamic range and center V_{REF} on the expected output dynamic range. As an example, say

that the expected input signal ($-IN$ – IN) is +1V to –2V. Under these conditions, the in amp's input buffers need to swing both positive and negative with respect to V_{CM} . Therefore, you must raise V_{CM} above ground for this scenario to happen. Assume that the in amp is operating at unity gain. Setting V_{CM} to 2V or a bit higher allows 2V of headroom in the minus direction. The trade-off is that there is now 2V less swing in the positive direction. If the in amp is operating with gain, tailor V_{CM} to allow the buffer outputs to swing fully without clipping.

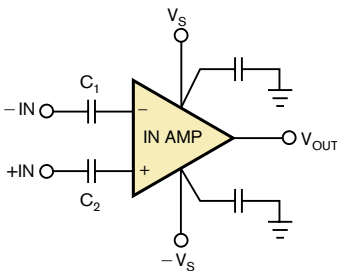

Figure 8 An incorrect procedure results in this nonfunctional, ac-coupled in-amp circuit.

Output centering is similar: Estimate the amount and direction of the in amp's output swing—in most cases, $V_{IN} \times \text{gain} + V_{CM}$ —and then apply a reference voltage at V_{REF} that is in the center of that range.

The choice of dc-return-resistor value for ac-coupled circuits is a trade-off between offset errors and the physical and electrical size of the input coupling capacitors. The larger the value of the input resistor, the smaller

the required input coupling capacitor. This approach saves both money and pc-board space. However, the trade-off is that high-value input resistors increase the offset-voltage error due to input offset currents. Offset-voltage drift and resistor noise also increase. With lower resistor values, higher value input capacitors for C_1 and C_2 are necessary to provide the same –3-dB corner frequency. That is: $F_{-3dB} = (1/(2\pi R_1 C_1))$, where $R_1 = R_2$ and $C_1 = C_2$.

Unless a large enough dc voltage is present on either side of the ac coupling capacitor, use nonpolarized capacitors. Some capacitors, such as electrolytics, function as diodes if you do not properly dc-bias them. In the interest of keeping components

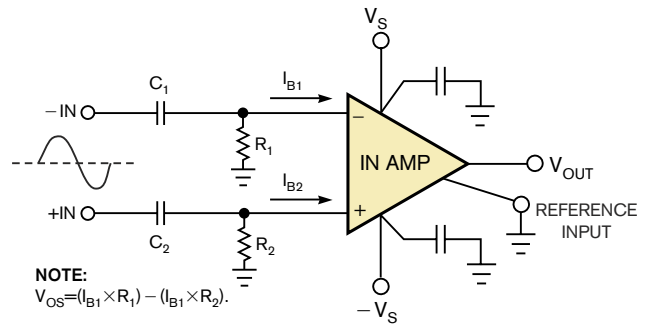

Figure 9 For dual-supply operation, a high-value resistor connected between each input and ground provides the necessary dc return path.

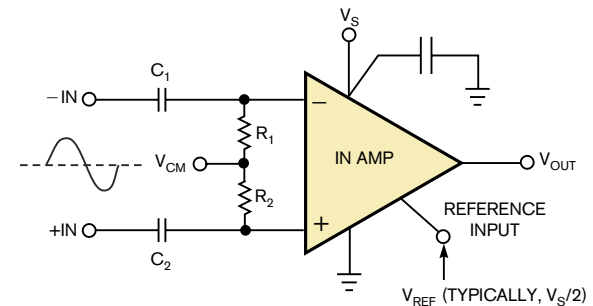

Figure 10 An ac-coupled, single-supply in-amp circuit normally requires a dc common-mode voltage, V_{CM} , applied to both inputs.

as small as possible, select capacitors of 0.1 μF or less. Generally, the lower the capacitor value, the less costly and smaller the capacitor is. The voltage rating of the input coupling capacitor needs to be high enough to avoid breakdown from any high-voltage input transients that might occur. One final word of caution: Avoid high-K (high-dielectric-constant) ceramic capacitors, which can introduce harmonic distortion.

When ac coupling, any mismatch between the two dc return resistors causes an input offset imbalance ($I_{B1} - I_{B2}$), which creates an input offset-voltage error (Figure 9). Table 1 gives R and C cookbook component values for various circuit bandwidths and the V_{OS} error for two levels of input-bias current. EDN

REFERENCE

Kitchin, Charles and Lewis Counts, *A Designer's Guide to Instrumentation Amplifiers, Second Edition*, available free from Analog Devices at www.analog.com/analog_root/static/technology/amplifiersLinear/InstrumentationAmplifiers/designersGuide.html.

AUTHORS' BIOGRAPHIES

Charles Kitchin is a hardware applications engineer for Analog Devices (Wilmington, MA). His main responsibilities include writing technical publications and developing applications circuits. He has published more than 80 technical articles and design ideas, three books, and numerous application notes.

Lew Counts is the vice president of the Advanced Linear Products Division of Analog Devices and was promoted to division fellow, one of Analog Devices' highest awards, in 1984.