

Single-ended-to-differential converter has resistor-programmable gain

Sandro Herrera and Moshe Gerstenhaber, Analog Devices, Wilmington, MA

Many applications—such as driving modern ADCs, transmitting signals over twisted-pair cables, and conditioning high-fidelity audio signals—require differential signaling to achieve higher signal-to-noise ratios, increased common-mode noise immunity, and lower second-harmonic distortion. This requirement presents a need for a circuit block that can convert single-ended signals to differential signals; that is, a single-ended-to-differential converter.

For many applications, an AD8476 precision, low-power, fully differential amplifier with integrated precision resistors is more than adequate to perform the single-ended-to-differential conversion function. For applications that require improved performance, however, an OP1177 precision op amp can be cascaded with the AD8476, as shown in Figure 1. This single-ended-to-differential converter has high input impedance; 2-nA (max) input bias current; 60- μ V (max) offset voltage, referred to the input; and 0.7- μ V/ $^{\circ}$ C (max) offset voltage drift, referred to the input.

The presented circuit is a two-amplifier feedback arrangement in which the op amp determines the circuit's precision and noise performance, while the differential amplifier performs the single-ended-to-differential conversion. This feedback arrangement suppresses the errors of the AD8476, including noise, distortion, offset, and offset drift, by placing the AD8476 inside the op amp's feedback loop, with the op amp's large open-loop gain preceding it. In essence, the arrangement attenuates the errors of the AD8476 by the open-loop gain of the op amp when referred to the input.

External resistors R_F and R_G set the gain of the single-ended-to-differential converter in Figure 1 such that

$$\text{GAIN} = \frac{V_{\text{OUT, DIFF}}}{V_{\text{IN}}} = 2 \left(1 + \frac{R_F}{R_G} \right).$$

A minimum gain of two can be achieved by replacing R_F with a short and R_G with an open.

As with any feedback connection, care must be taken to ensure the system is stable. The cascade of the OP1177 and the AD8476 forms a composite differential-out op amp whose open-loop gain over frequency is the product of the OP1177's open-loop gain and the AD8476's closed-loop gain. The closed-loop bandwidth of the AD8476, therefore, adds a pole to the open-loop gain of the OP1177. To ensure stability, the bandwidth of the AD8476 should be higher than the unity-gain frequency of the OP1177. This requirement is relaxed when the circuit is in a closed-loop gain greater than two, because the

resistor feedback network effectively reduces the unity-gain frequency of the OP1177 by a factor of $R_G/(R_G + R_F)$. The AD8476 has a bandwidth of 5 MHz, and the OP1177 has a unity-gain frequency of 1 MHz, so the circuit shown does not exhibit stability issues at any gain.

When using an op amp with a unity-gain frequency that is much larger than the differential amplifier's bandwidth, you can insert a bandwidth-limiting capacitor, C_F , as shown in Figure 1. Capacitor C_F forms an integrator with the feedback resistor R_F such that the bandwidth of the overall circuit is given by

$$\text{BANDWIDTH} = \frac{1}{2} \left(\frac{1}{2\pi R_F C_F} \right).$$

The factor of one-half in the bandwidth equation is due to the circuit's output being fed back single-endedly rather than differentially. As a result, the circuit's feedback factor and bandwidth are reduced by two.

If this reduced bandwidth is lower than the closed-loop bandwidth of the differential amplifier, the circuit will be stable. This bandwidth-limiting technique also can be employed with a gain of two by making R_G an open circuit. EDN

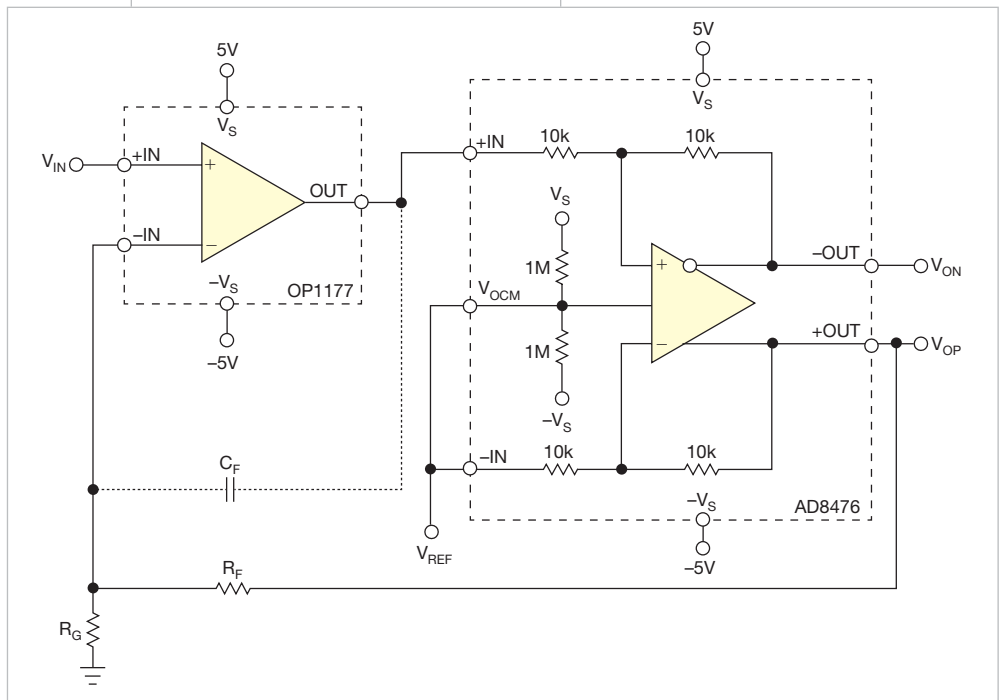

Figure 1 You set the gain of this single-ended-to-differential converter by adjusting the ratio of R_F to R_G .