

A Low-Noise Precision Op Amp

National Semiconductor
Linear Brief 52
Robert A. Pease



It is well known that the voltage noise of an operational amplifier can be decreased by increasing the emitter current of the input stage. The signal-to-noise ratio will be improved by the increase of bias, until the base current noise begins to dominate. The optimum is found at:

$$I_{e(\text{optimum})} = \frac{KT}{q} \frac{\sqrt{h_{FE}}}{r_s}$$

where r_s is the output resistance of the signal source. For example, in the circuit of *Figure 1*, when $r_s = 1 \text{ k}\Omega$ and $h_{FE} = 500$, the I_e optimum is about $500 \mu\text{A}$ or $560 \mu\text{A}$. However, at this rich current level, the DC base current will cause a significant voltage error in the base resistance, and even after cancellation, the DC drift will be significantly bigger than when I_e is smaller. In this example, $I_b = 1 \mu\text{A}$, so $I_b \times r_s = 1 \text{ mV}$. Even if the I_b and r_s are well matched at each input, it is not reasonable to expect the $I_b \times r_s$ to track better than 5 or $10 \mu\text{V}/^\circ\text{C}$ versus temperature.

A new amplifier, shown in *Figure 2*, operates one transistor pair at a rich current, for low noise, and a second pair at a much leaner current, for low base current. Although this looks like the familiar Darlington connection, capacitors are added so that the noise will be very low, and the DC drift is very good, too. In the example of *Figure 2*, Q2 runs at $I_e = 500 \mu\text{A}$ and has very low noise. Each half of Q1 is operated at $11 \mu\text{A} = I_e$. It will have a low base current (20 nA to 40 nA typical), and the offset current of the com-

posite op amp, $I_{b1} - I_{b2}$, will be very small, 1 nA or 2 nA. Thus, errors caused by bias current and offset current drift vs. temperature can be quite small, less than $0.1 \mu\text{V}/^\circ\text{C}$ at $r_s = 1000\Omega$.

The noise of Q1A and Q1B would normally be quite significant, about $6 \text{ nV}/\sqrt{\text{Hz}}$, but the $10 \mu\text{F}$ capacitors completely filter out the noise. At all frequencies above 10 Hz, Q2A and Q2B act as the input transistors, while Q1A and Q1B merely buffer the lowest frequency and DC signals.

For audio frequencies (20 Hz to 20 kHz) the voltage noise of this amplifier is predicted to be $1.4 \text{ nV}/\sqrt{\text{Hz}}$, which is quite small compared to the Johnson noise of the $1 \text{ k}\Omega$ source, $4.0 \text{ nV}/\sqrt{\text{Hz}}$. A noise figure of 0.7 dB is thus predicted, and has been measured and confirmed. Note that for best DC balance $R_6 = 976\Omega$ is added into the feedback path, so that the total impedance seen by the op amp at its negative input is $1 \text{ k}\Omega$. But the 976Ω is heavily bypassed, and the total Johnson noise contributed by the feedback network is below $\frac{1}{2} \text{ nV}/\sqrt{\text{Hz}}$.

To achieve lowest drift, below $0.1 \mu\text{V}/^\circ\text{C}$, R1 and R2 should, of course, be chosen to have good tracking tempco, below 5 ppm/ $^\circ\text{C}$, and so should R3 and R4. When this is done, the drift referred to input will be well below $0.5 \mu\text{V}/^\circ\text{C}$, and this has been confirmed, in the range $+10^\circ\text{C}$ to $+50^\circ\text{C}$. Overall, we have designed a low-noise op amp which can rival the noise of the best audio amplifiers, and at the same

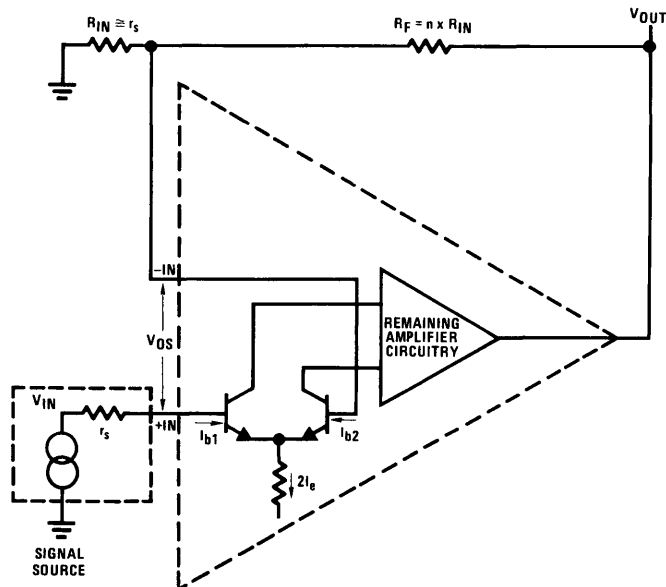

$$V_{OUT} = (n+1)V_{IN} + V_{OS} \times (n+1) + (I_{b2} - I_{b1}) \times r_s \times (n+1) + V_{\text{noise}} \times (n+1) + I_{\text{noise}} \times (r_s + R_{IN}) \times (n+1)$$

TL/H/8499-1

FIGURE 1. Conventional Low-Noise Operational Amplifier

time exhibits drift characteristics of the best low-drift amplifiers. The amplifier has been used as a precision pre-amp (gain = 1000), and also as the output amplifier for a 20-bit DAC, where low drift and low noise are both important.

To optimize the circuit for other r_s levels, the emitter current for Q2 should be proportional to $1/\sqrt{r_s}$. The emitter current of Q1A should be about ten times the base current of Q2A. The base current of the output op amp should be no more than 1/1000 of the emitter current of Q2. The values of R1 and R2 should be the same as R7.

Various formulae for noise:

$$\text{Voltage noise of a transistor, per } \sqrt{\text{Hz}}, e_n = KT \sqrt{\frac{2}{qI_C}}$$

$$\text{Current noise of a transistor, per } \sqrt{\text{Hz}}, i_n = \sqrt{\frac{2qI_C}{h_{FE}}}$$

$$\text{Voltage noise of a resistor, per } \sqrt{\text{Hz}}, e_n = \sqrt{4KTR_s}$$

For a more complete analysis of low-noise amplifiers, see AN-222, "Super Matched Bipolar Transistor Pair Sets New Standards for Drift and Noise", Carl T. Nelson.

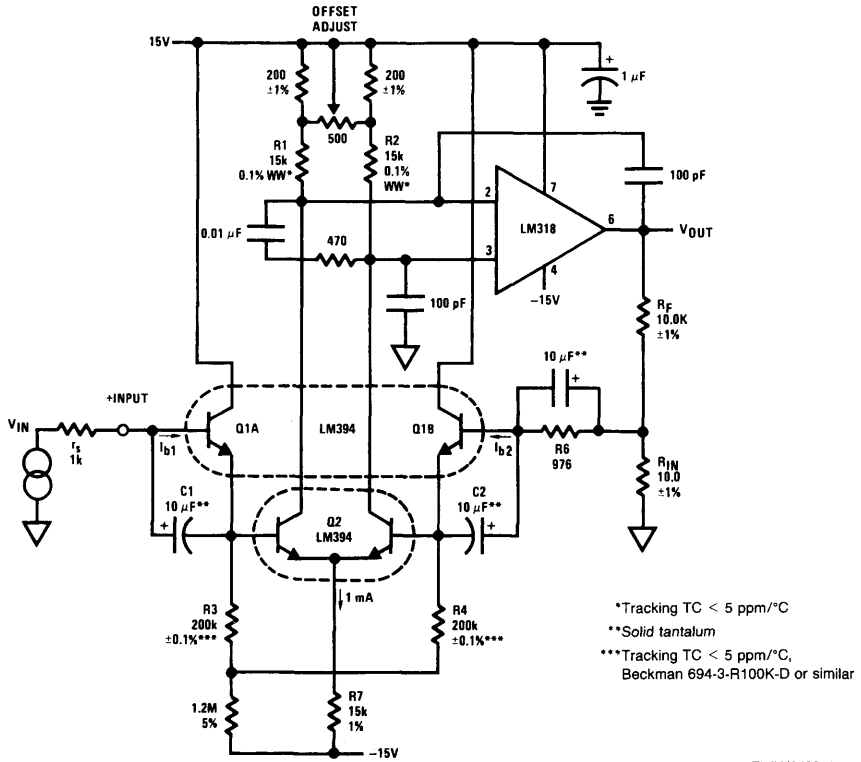

FIGURE 2. New Low-Noise Precision Operational Amplifier as Gain-of-1000 Pre-Amp

TL/H/8499-2