

Low Drift Amplifiers

National Semiconductor
Linear Brief 22



INTRODUCTION

Since the introduction of the monolithic IC amplifier, there has been a continued improvement in DC accuracy. Bias currents have been decreased by five orders of magnitude over the past five years. Low offset voltage drift is also necessary in high-accuracy circuits. This is evidenced by the popularity of low-drift amplifier types as well as requests for selected low-drift op amps. However, little has been written about the problems associated with handling microvolt signals with a minimum of errors.

A very low drift amplifier poses some uncommon application and testing problems. Many sources of error can cause the apparent circuit drift to be much higher than would be predicted. In many cases, the low drift of the op amp is completely swamped by external effects while the amplifier is blamed for the high drift.

Thermocouple effects caused by temperature gradient across dissimilar metals are perhaps the worst offenders. Whenever dissimilar metals are joined, a thermocouple results. The voltage generated by the thermocouple is proportional to the temperature difference between the junction and the measurement end of the metal. This voltage can range between essentially zero and hundreds of microvolts per degree, depending on the metals used. In any system using integrated circuits, a minimum of three metals are found: copper, solder, and kovar (lead material of the IC).

Nominally, most parts of the circuit are at the same temperature. However, a small temperature gradient can exist across even a few inches—and this is a big problem with the low level signals. Only a few degrees gradient can cause hundreds of microvolts of error. Two places where this shows up, generally, are the package-to-printed-circuit-board interface and temperature gradients across resistors. Keeping package leads short and the two input leads close together help greatly.

For example, a very low drift amplifier was constructed and the output monitored over a 1-minute period. During the one minute it appeared to have input referred offset variations of $\pm 5.0 \mu\text{V}$. Shielding the circuit from air currents reduced this to $\pm 0.5 \mu\text{V}$. The $10 \mu\text{V}$ error was due to thermal gradients across the circuit from air currents.

Resistor choice as well as physical placement is important for minimizing thermocouple effects. Carbon, oxide film, and some metal-film resistors can cause large thermocouple errors. Wirewound resistors of even ohm or managanin are best since they only generate about $2.0 \mu\text{V}/^\circ\text{C}$ referenced to copper. Of course, keeping the resistor ends at the same temperature is important. Generally, shielding a low-drift stage electrically and thermally yields good results.

Resistors can cause other errors besides gradient generated voltages. If the gain setting resistors do not track with temperature, a gain error will result. For example, a gain-of-1000 amplifier with a constant 10 mV input will have 10V output. If the resistors mistrack by 0.5% over the operating temperature range, the error at the output is 50 mV. Referred to input, this is a $50 \mu\text{V}$ error. Most precision resistors use different material for different ranges of resistor values. It is not unexpected that a resistor differing by a factor of 1000 does not track perfectly with temperature. For best

results, ensure that the gain fixing resistors are of the same material or have tracking temperature coefficients.

It is appropriate to mention offset balancing as this can have a large effect on drift. Theoretically, the drift of a transistor differential amplifier depends on the offset voltage. For every millivolt of offset voltage the drift is $3.6 \mu\text{V}/^\circ\text{C}$. Therefore, if the offset is nulled, the drift should be zero. When working with IC op amps, this is not the case. Other effects, such as second stage drift and internal resistor TC, make the drift nontheoretical.

Certain types of amplifiers are optimized to have lower drift with offset balancing such as the LM121 and LM725. With this type of device offset, nulling improves the drift, and offset nulling should be used. Other types of devices, such as selected LM741's or LM308's, are selected for the drift without offset nulling connected to the device. The addition of a balancing network changes the internal currents and thus changes the drift—probably for the worse—so any offset balancing should be done at the input.

No matter which null network is applied, highly stable resistors must be used. They should have low TC and track. Wirewound pots are usually a good choice. Finally, when the null network reduces a drift, the balancing of the amplifier as close to zero offset as possible minimizes the drift.

Testing low-drift amplifiers is also difficult. Standard drift testing techniques such as heating the device in an oven and having the leads available through a connector, thermoprobe, or the soldering iron method do not work. Thermal gradients can cause much greater errors than the amplifier drift. Coupling microvolt signal through connectors is especially bad since the temperature difference across the connector can be 50°C or more. The device under test, along with the gain setting resistor, should be isothermal. The circuit in Figure 1 will yield good results if well constructed.

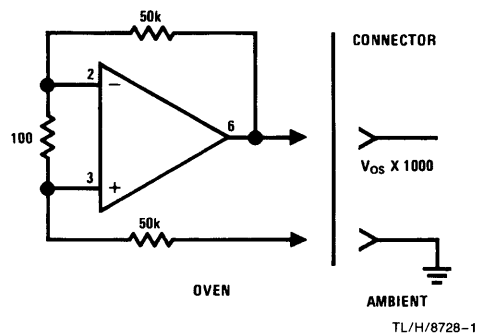

FIGURE 1. Drift Measurement Circuit

CONCLUSION

Low-drift amplifiers need extreme care to achieve reproducible low drift. Thermal and electrical shielding minimize thermocouple effects. Resistor choice is also important as they can introduce large errors. Careful attention to circuit layout offset balancing circuitry is also necessary.