

Get Fast Stable Response From Improved Unity-Gain Followers

In many applications, a unity-gain follower (e.g. any operational amplifier with tight feedback to the inverting input) may oscillate or exhibit bad ringing when required to drive heavy load capacitance. For example, the LM110 follower will normally drive a 50 pF load capacitor, but will not drive 500 pF, because the open-loop output impedance is lagged by such a large capacitive load. The frequency at which this lag occurs is comparable to the gain-bandwidth product of the amplifier, and when the phase margin is decreased to zero, oscillation occurs.

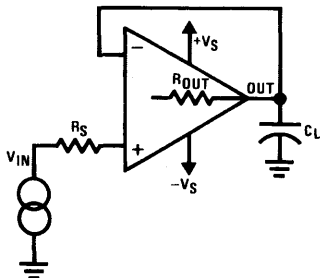

TL/H/8491-1

FIGURE 1. Unity-Gain Follower Attempting to Drive Capacitive Load

While the solution to this problem is not widely known, an analysis of the general problem shown in *Figure 2* can lead to a useful approach. It is generally known that increasing the noise gain of an op amp's feedback network will improve tolerance of capacitive load. In *Figure 2*, adding a resistor $R_2 \cong R_F/10$ will do this. (A moderate capacitor C_2 is usually inserted in series with R_2 , to prevent the DC noise gain from increasing also—to avoid degrading DC offset, drift and inaccuracy.) If the op amp has a 1 MHz gain bandwidth product, and $R_1 = R_F$, the closed-loop frequency response will be $\frac{1}{2}$ MHz. Adding $R_2 = R_F/10$ will drop the closed-loop frequency response to 90 kHz, where the amplifier can usually tolerate a much larger C_L ;

$$\text{Noise Gain} = \frac{R_F}{R_1} + \frac{R_F}{R_2} + 1 \quad (\text{AC})$$

$$\text{Noise Gain} = \frac{R_F}{R_1} + 1 \quad (\text{DC})$$

National Semiconductor
Linear Brief 42
Robert A. Pease

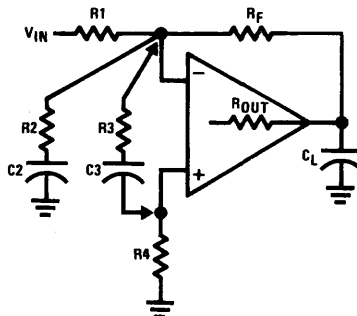

TL/H/8491-2

FIGURE 2. Stabilizing an Operational Amplifier for Capacitive Load

A similar result will occur if you install R_3 and C_3 , instead of R_2 . Now the (AC) noise gain will be:

$$1 + \frac{R_4}{R_3} + \frac{R_F}{R_3} + \left(\frac{R_F}{R_1} \right) \left(\frac{R_3 + R_4}{R_3} \right)$$

As a simplification, if R_1 is an open circuit, the AC noise gain will be: $(R_4/R_3 + R_F/R_3 + 1)$. Now it can be seen that noise gain can be raised by having a low value of R_3 and a high value of R_4 or R_F (or both).

In particular, where R_F is required to be 0Ω , as in a follower, the noise gain can be raised by adding a large R_4 and a small R_5 , as shown in *Figure 3*. If R_S is low, the AC noise gain will be $R_4/R_5 + 1$. (If R_S is large and constant, R_4 may be unnecessary, and the noise gain would then be $R_S/R_5 + 1$.) For LM110/LM310's $R_4 = 10\text{ k}\Omega$ is recommended and when $R_5 = 3.3\text{ k}\Omega$, $C_5 = 200\text{ pF}$, the LM110 will stably drive C_L up to 600 pF.

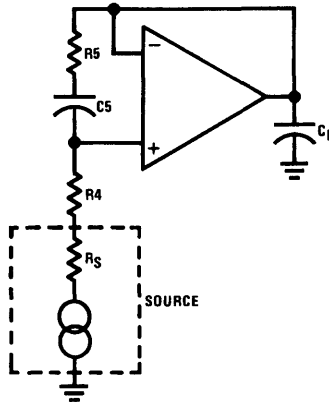

TL/H/8491-3

FIGURE 3. Stabilizing a Unity-Gain Follower for Capacitive Load

Another application of this technique is for making a fast follower with a high slew rate. An LF356 is specified as a follower, but an LF357 must be applied at an "A_v = 5" minimum, because it has been "decompensated" with a smaller internal capacitor. Most people do not realize how easy it is to apply an LF357 as a follower. In *Figure 4*, an LF357 will have fast, stable response just like an LF356 does, when R_S is < 1 kΩ, but it will have a 50V/μs slew rate (typical) vs. 12V/μs for an LF356.

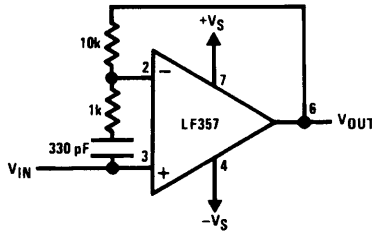

TL/H/8491-4

FIGURE 4. Unity-Gain Follower With Fast Slew Rate

Similarly, an LM348 is a fast decompensated quad op amp. Its bipolar input stage has a finite bias current, 200 nA max. For best results, the resistance which makes up the noise gain should be put equally in the **plus** and **minus** input circuits, as shown in *Figure 5*. The LM349 can slew at 2V/μs typical, and is much faster for handling audio signals without distortion than the LM348 (which at 0.5V/μs is only as fast as an ordinary LM741). The same approach can be used for an LM101 with a 5 pF damping capacitor. While these circuits give faster slewing, the bandwidth may degrade if the source impedance R_S increases. Also, when the AC noise gain is raised, the AC noise will also be increased. While most modern op amps have low noise, a noise gain of 10 may make a significant increase in output noise, which the user should check to insure it is not objectionable.

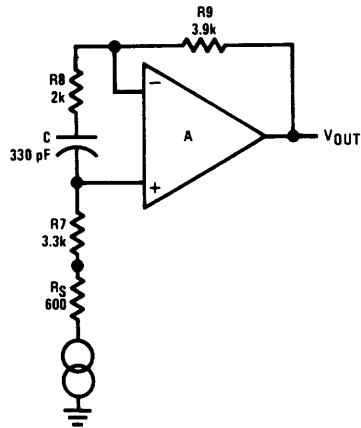

TL/H/8491-5

FIGURE 5. Application of Fast Follower With Balanced Resistors, R₉ = R₇ + R₆, A = 1/4 LM349 (or LM101 with 5 pF Capacitor)

If the series capacitor is much larger than necessary, noise will be increased more than necessary. In general, choose the C₅ for *Figure 3*, (e.g.) per these guidelines: (where f_v = unity-gain bandwidth of op amp)

$$C5 \text{ Min} = \frac{4 \cdot \left(1 + \frac{R4}{R5}\right)}{2\pi R5 \cdot f_v} = \frac{R4 + R5}{\frac{\pi}{2} \cdot f_v \cdot (R5)^2}$$

For best results, choose the design center value of C₅ to be 2 or 3 times C₅ min.