

Use dual op amp in an instrumentation amp

Jerald Graeme, Burr-Brown Corp, Tucson, AZ

Editor's note: Here's an oldie but goodie. EDN editors regularly field requests for copies of articles that predate our online archives (www.edn.com/archives). But this Design Idea from our Feb 20, 1986, issue has generated many more requests than normal. We aren't sure how readers know of this Design Idea, but its enduring popularity has led us to publish it once again, and now it will be available in our online archives.



Although monolithic instrumentation amplifiers are more cost-effective than their discrete and modular predecessors, the limited variety of monolithic instrumentation amps restricts their use. You can widen

your options, however, by deriving the differential response of an instrumentation amplifier from a dual op amp (**Figure 1**). The circuit uses FET-input op amps to provide lower noise and lower input-bias currents than monolithic instrumentation amps can offer.

In **Figure 1**, feedback networks for the two op amps are interconnected to establish IC_{1B} as an inverting amplifier in the feedback path of IC_{1A} . Each amplifier provides an external signal input with the high impedance expected of an instrumentation amplifier. (Input-bias currents for this circuit are 2 pA at 25°C.)

Feedback from each amplifier forces

a voltage ($V_1 - V_2$) across the gain-setting resistor R_G . Signal current in the combined feedback path is thus proportional to the differential input voltage and inversely related to R_G . The output voltage, V_{OUT} , equals $G(V_1 - V_2)$ —that is, $V_{OUT} = 2(1 + R/R_G)(V_1 - V_2)$.

You choose R_G for the desired gain G , which may range from a value of 2 (R_G omitted) to a maximum that is limited only by the op amps' open-loop gain, the allowable gain error, and the required bandwidth. The **Figure 1** circuit provides a 2-kHz bandwidth at a gain of 2000; in general, the bandwidth is about 2 MHz/G. What's more, the output offset equals the difference in op-amp offsets multiplied by G .

The dc CMR (common-mode rejection) is an important spec for instrumentation amps; in **Figure 1**, CMR depends primarily on matching values for the four resistors labeled R. DC CMRR

(common-mode rejection ratio) is the reciprocal of the net fractional resistor mismatch; that is, 10,000-to-1 (-80 dB) for a 0.01% mismatch. AC CMR, on the other hand, is limited by the op amps' unequal feedback factors. The network within the shaded region lets you compensate for the effect of unequal feedback factors where necessary—in applications in which the frequency of common-mode voltage exceeds the useful frequency range for signals.

Finally, note that op amp IC_{1B}'s output (the combined differential

Correction: In the print version of the Dec 15, 2006, Design Idea "Magnetic-field probe requires few components," we inadvertently omitted the byline of one of the Design Idea's primary authors: Sandeep M Satav. You can read this Design Idea and see the correct bylines online at www.edn.com/article/CA6399102. We apologize for the error.

and common-mode signals) has a wider swing than V_{OUT}. Consequently, this output—equal to 2V₁+(R/

R_G)(V₁-2V₂)—must remain within the op amp's common-mode range to ensure linear operation. **EDN**

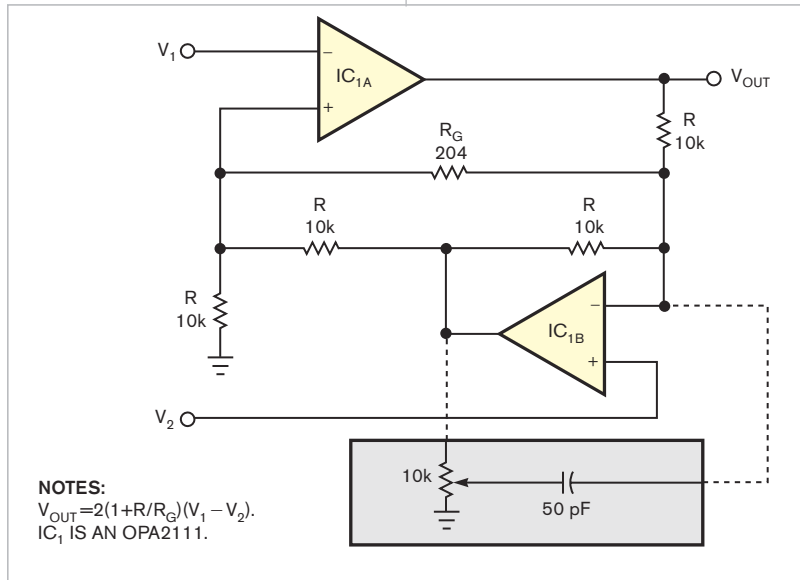

Figure 1 You can build an instrumentation amplifier by providing a common feedback path for the two sides of a dual op amp.