



990 Discrete Op-Amp

April 6, 2013

The 990 discrete op-amp is the finest op-amp available for audio applications. If you want superior sound quality, the 990 can provide it. The 990 is used in the most critical audio applications. Several mic preamps and other products using the 990 are available from the John Hardy Company.

Circuit design of the original 990 is by Deane Jensen of Jensen Transformers. Deane was awarded U.S. patent #4,287,479 for aspects of this design. Every aspect of the design and performance of the 990 was optimized through extensive computer aided design and analysis. Each component of this discrete op-amp was carefully chosen for its specific task, providing superior performance compared to monolithic op-amps and other discrete op-amps. For complete design theory, circuit details and specifications, please see the Jensen engineering report. The "C" modifications were developed by Steve Hogan of Jensen Transformers (now at his own company, [The Sound Steward](#)).

Packaging and production design of the 990 is by John Hardy of the John Hardy Company. The design enables this 49-component circuit to be constructed on a circuit board 1" square, with final module dimensions after encapsulation of 1.125" square by 0.600" high. The dimensions and pinouts conform to the API 2520 package, allowing direct replacement in most applications.

2013: Important Changes and Improvements

In January of 2013, manufacturing of the 990 was converted from through-hole assembly to surface-mount assembly. Many improvements in components were made. The basic circuit and package dimensions remain the same, but the name has been modified to "990C+" to signify the changes.

These changes and improvements were made as the result of a series of events:

1. A key component of the 990, the National Semiconductor LM394 supermatched pair of transistors, was discontinued in 2010. Fortunately, there were two devices that were very suitable replacements for the LM394, providing virtually identical performance: the Analog Devices MAT02 and SSM2210. Originally the MAT02 was a Precision Monolithics part, the SSM2210 a Solid State Microtechnology part. PMI bought SSM in the late 1980s, Analog Devices bought PMI in 1990. The same semiconductor chip was used in the MAT02 and SSM2210, with PMI using SSM to access broader markets for the supermatched pair.

2. Analog Devices unexpectedly discontinued the MAT02 and SSM2210. This left no suitable supermatched pairs of transistors available. As the story goes, sales were declining on these and other old-school "analog" parts, so National Semiconductor and Analog Devices decided to discontinue them and close the outdated fabrication plants where they were made.

3. Analog Devices reversed its decision and reintroduced their parts under new part

numbers, moving the manufacturing to a modern fab plant. The MAT02 is now the MAT12, the SSM2210 is now the SSM2212.

4. As with the original parts, the reintroduced versions are made from the same semiconductor chip, the only differences being the packaging and the price. The specifications of the new parts are identical.

5. Packaging: The MAT12 uses a through-hole 6-lead TO-78 package, the SSM2212 uses a surface-mount SO-8 package.

6. Price: The LM394 was always around \$3 at the 1,000-piece quantity. The SSM2212 is also around \$3 at the 1k quantity. The MAT12 is around \$15 at the 1k quantity.



Since the MAT12 is five times the price of the SSM2212 (and LM394), yet provides no advantage in performance, the decision was made to use the lower-cost SSM2212 and convert the 990 to surface mount assembly.

The conversion to surface-mount assembly enabled several improvements in components:

1. Most of the resistors have been upgraded from metal-film resistors with a 1% tolerance and a 50 or 100ppm temperature coefficient to thin-film resistors with a 0.1% tolerance and a 25ppm tempco for improved performance.

2. The three small-value capacitors (C1, C2 and C3) in the signal path have been upgraded from a 5% tolerance to 1%, still using the superior COG/NP0 ceramic dielectric.

3. The two power supply bypass capacitors (C4 and C5) have been upgraded from the X7R ceramic dielectric with a 10% tolerance to the superior COG/NP0 ceramic dielectric with a 5% tolerance.

4. C6 (in the current-source) has been upgraded from a film dielectric with a 5% tolerance to the COG/NP0 ceramic dielectric with a 5% tolerance.

5. The two 20μH inductors (L1 and L2) have been upgraded to a tighter tolerance in a smaller surface-mount package, making a shorter 990 package possible as an option.

6. Transistors Q3 and Q10 in the current mirror have been upgraded to a matched-pair for improved performance.

7. The encapsulant has been changed from silicone to an advanced epoxy encapsulant that has high thermal conductivity and is compatible with the special demands of surface-mount packaging.

Technical Details

Discrete vs. monolithic op-amps. An op-amp typically consists of dozens of diverse components, including transistors, diodes, resistors, capacitors and, occasionally, inductors. The fundamental difference between a discrete op-amp and a monolithic op-amp is the way these diverse components are brought together to make a working op-amp.

A discrete op-amp is made from individual (discrete) transistors, diodes, resistors, capacitors, and, occasionally, inductors. These components are brought together on a circuit board or substrate to create the final circuit. Each diverse component is fabricated on a manufacturing line that is fully optimized for that specific part. Therefore, each component is the very best it can be. Low-noise input transistors are fully optimized for their unique requirements. High-power output transistors are fully optimized for their unique and very different requirements. Precision resistors come from manufacturing lines that are dedicated to making precision resistors. Capacitors come from optimized capacitor lines. Only after these fully optimized components are fabricated are they brought together on a circuit board or substrate.

A monolithic op-amp starts with a single chip (monolith) of silicon that is typically 1/16" square. This chip is the substrate upon which the dozens of diverse components are created. Note that all components are created on the same chip, and you simply cannot have the world's best input transistors, and the world's best output transistors, and precision resistors and capacitors on the same tiny chip. There are unavoidable compromises due to limitations in the fabrication process. If the process is optimized for low-noise input transistors, there will likely be a compromise in the high-power output transistors, etc. Each of the two inductors in the 990 (L1 and L2 on the 990 schematic, page 3) is many times larger than the 1/16" square chip of silicon of a typical monolithic op-amp.

Even the small size of the typical silicon chip is a limiting factor. To fit all of the parts on such a small chip they must be made much smaller than might otherwise be desired. The reduced size causes a reduced ability to dissipate heat. The closer spacing of components and circuit traces reduces the maximum voltage levels that the circuit can tolerate.

Monolithic op-amps are marvels of technology, but when performance is critical, they cannot match a discrete op-amp. A discrete op-amp costs more and is larger than a monolithic op-amp, but it offers superior performance in many ways:

Lower noise. The 990 is an extremely quiet op-amp, particularly with low source impedances. This can provide as much as 8dB of improvement in signal-to-noise ratios in summing amp applications, compared to the popular 5534 monolithic op-amp.

The 990 provides extremely low noise when used in mic preamps. The John Hardy Company manufactures the M-1, M-2, and Jensen Twin Servo® 990 Mic Preamps, and several mic preamp cards using the 990. The application notes later in this package include a schematic of the mic preamp circuitry of the M-1 and a discussion of circuit details. (®Trademark, Jensen Transformers).

One of the reasons the 990 is so quiet is its use of the Analog Devices SSM2212 supermatched transistor pair for the input pair of transistors (Q1 and Q2 on the 990 schematic). The silicon chip of the SSM2212 is about 1/16" square, the same size as the entire chip of a typical monolithic op-amp! The large size provides very low noise. Analog Devices used whatever size chip was required to make the finest possible supermatched pair.

The input pair of transistors in an op-amp should be as closely matched in performance as possible. The SSM2212 is ideal as an input pair because both transistors of the pair are fabricated on the same chip of silicon, thus greatly reducing performance differences that would exist between separate chips of silicon. This is a unique situation where the monolithic process is superior to discrete, creating multiple transistors side-by-side on the same substrate for optimum matching. In fact, there are four transistors on the chip: the upper-left and lower-right transistors connected in parallel to form "Q1", the remaining two transistors connected in parallel to form "Q2", further reducing even the slight variations that might exist across the same chip.

High output power. The 990 provides much higher output power than monolithic op-amps. This is because the MJE-181 and MJE-171 discrete output transistors (Q8 and Q9) are much larger than the ones found in monolithic op-amps (and some other discrete op-amps), so they can handle much more power. They were designed from the ground up as power transistors. They use a silicon chip that is as large as the chip in a typical monolithic op-amp. The chip is attached to a metal back-plate for improved heat dissipation. Each transistor is about as large as an 8-pin DIP op-amp. The **990C+** still uses the through-hole MJE-171/181 parts.

Then the 990 package comes into play. The metal back-plates of the MJE-181 and MJE-171 transistors are bonded to the aluminum shell of the 990 using a high thermal conductivity epoxy. This provides exceptional heat-sinking of the transistors. The 990 package has about 14 times the surface area of a typical 8-pin DIP op-amp, greatly increasing its ability to dissipate heat. It is easy to see how the 990 can handle much higher power levels than the typical monolithic op-amp. In fact, the 990 can drive 75Ω loads to full output level, while monolithic op-amps are limited to loads of 600Ω at best, and more typically 2kΩ. Some discrete op-amps use much smaller output transistors than the MJE-181 and MJE-171. The transistors have smaller chips and are lacking a metal back plate critical for heat dissipation. They cannot handle as much power as the MJE-181 and MJE-171.

The ability to drive lower-impedance loads is important for two reasons. First, the 990 can easily drive multiple power amps, or pots, etc., with less concern for cumulative loading. Second, the resistors, capacitors and other parts that are connected around the 990 to determine the function of the circuit can be scaled down to much lower impedances than those of a monolithic design. This can result in lower noise. Some monolithic op-amps are theoretically capable of very low noise performance, but they cannot drive low impedances without increased distortion or decreased headroom, compromising performance.

Low noise and high output power. When you have both low noise and high output power in the same op-amp, you can often eliminate extra op-amp stages in equipment. Using the M-1 mic preamp as an example, the 990 provides the extremely low noise that is required in a mic preamp, and the high output power that is required in a line driver or main output stage. There is no need to have two stages – one for low noise and one for high output power. The signal path is shorter, resulting in less signal degradation. Discrete op-amps cost more than monolithics, but when you use fewer of them, the higher cost is less of a factor.

Higher voltage ratings. The components of the 990 discrete op-amp can handle higher voltages than those in most monolithic op-amps. This allows the 990 to operate with ±24V power supplies, while the typical monolithic op-amp is limited to ±18V supplies. It is common for monolithic op-amps to be operated at ±15V, sometimes even ±12V. In audio terms, this means that the monolithic op-amps have reduced headroom. The 990 with ±24V power supplies is capable of output levels of greater than +24dBu, while most monolithic op-amps clip several dB below that due to the reduced power supply voltages.

Precision passive parts. The 990 uses 0.1%, 0.5% and 1% tolerance metal film resistors with tempcos of 25 or 50ppm, and ultra-stable COG/NP0 ceramic capacitors with specifications superior to those typically found in monolithic op-amps. See the special report about COG/NP0 ceramic capacitors on page 8.

It sounds better! Most important of all is the fact that the 990 sounds better than monolithic op-amps. The 990 does not suffer from the many compromises of the monolithic manufacturing process. Some people think that solid-state equipment is cold and harsh sounding. Not the 990!

Applications. The 990 offers the finest performance in summing amps, mic preamps, phono preamps, tape-head preamps, A/D and D/A converters, equalizers and line drivers. The sensitivity of measurement equipment can be increased by the low noise of the 990. Application notes start on page 4.

Evolution of Models. There are three versions of the 990: The original 990, the 990A and the 990C. The original 990 was introduced in 1979. The 990A and 990C were introduced in 1987. The "A" version adds three components to the original 990 circuit to provide protection in the rare event the positive power supply is lost while the op-amp is driving an extremely low DC impedance such as the primary of an output transformer. Under those conditions the original 990 circuit would consume higher than normal current from the negative supply. The "A" modification prevents the excess current flow. The 990C is a further development of the "A" version, allowing the op-amp to operate over a wide range of power supply voltages. Other additional components provide reduced offset voltage. See the schematic on page 3 for details. **Note that the 990C+ is the only model in regular production. Other versions are special order only.**

Model #	Description
990C+	Standard 0.6" height of potting shell
990C+ (Short)	Shorter 0.4" height of potting shell

Package details. The 990 is packaged in a black-anodized aluminum potting shell filled with an advanced epoxy encapsulant that is compatible with the demands of surface mount packaging. The metal back plates of the power transistors are bonded directly to the aluminum shell, assuring maximum heat sinking of the transistors. The black anodized finish of the shell provides maximum thermal emission. The aluminum shell distributes heat evenly across the entire circuit. The package measures 1.125" x 1.125" x 0.600" (LxWxH), not including the pin extension of 0.233". The package is fully compatible with the API 2520 op-amp. A shorter package is available: 1.125" x 1.125" x 0.400" (LxWxH) for applications where space is limited. Pins are 0.040"D, gold/nickel plated.

Reliability. To ensure long-term reliability at temperature extremes, most resistors are 0.1% with a tempco of ± 25 ppm. All capacitors are ultra-stable (± 30 ppm) ceramics with the COG/NP0 dielectric. NOTE: Please see the special report on ceramic capacitors on page 8 for important information on this superior formulation. All modules receive a

total of 48 hours of active burn-in at 100°C (212°F).

Upgrades from the original Jensen Design. Many of the components listed in the Jensen engineering report were upgraded in the 990 made by the John Hardy Company to ensure long-term reliability at temperature extremes: Deane Jensen specified 5% tolerance carbon-film resistors. These were upgraded to 1% metal film with a 50 or 100ppm tempco in 1979. In 2013, most of them were further upgraded to 0.1% thin-film with a 25ppm tempco. Certain 0.1% resistors are trimmed to a higher degree of accuracy using proprietary trimming procedures.

C1, C2 and C3 are ultra-stable (± 30 ppm) COG/NP0 ceramic capacitors. See the report on ceramic capacitors on page 8. C4 and C5, which are not in the audio signal path, were upgraded from Y5V to X7R ceramic in 1979. In 2013 they were further upgraded to the superior COG/NP0 ceramic.

CR3 (1N914B diode) was replaced with a diode-connected PN4250A transistor (labeled as Q10) as suggested in the Jensen engineering report. This provides better matching with Q3, also a PN4250A. In 2013, these two transistors were replaced with a matched pair surface-mount package.

Other information. Thermal coupling aids as listed in the Jensen engineering report are unnecessary because components requiring thermal coupling are in direct contact with each other. High thermal conductivity epoxy is used to complete the coupling process.

R15 and L2 ("output isolator") are not part of the basic op-amp "triangle" and are not included in the 990 as manufactured by the John Hardy Company. They are available separately and are recommended in many applications for best results. See the Jensen engineering report for details.

990C Specifications (0dBu = 0.775V)

Measurement	Spec.	Units
Open-loop gain, DC to 30Hz	125	dB
Gain error at 100dB gain	0.4	dB
Noise-voltage spectral density, each transistor	0.8	nV/ $\sqrt{\text{Hz}}$
Noise-voltage spectral density, differential pair	1.13	nV/ $\sqrt{\text{Hz}}$
Noise current spectral density	1	pA/ $\sqrt{\text{Hz}}$
Noise index, 1k Ω source resistance	0.6	dB
Equivalent input noise voltage, 20kHz bandwidth, shorted input	160	nV
Corresponding voltage level	-133.7	dBu
Maximum input voltage at unity gain	13.8	V
Corresponding voltage level	+25	dBu
Input impedance, non-inverting input	>10	M Ω
Input bias current (typical)	+2.2	μA
Maximum output voltage, RL = 75 Ω	13.8	V
Corresponding voltage level	+25	dBu
Maximum peak output current	260	mA
Total harmonic distortion at 20kHz, VOUT = +24dBu		
RL = 75 Ω , gain = 40dB	0.06	%
RL = 75 Ω , gain = 20dB	0.005	%
RL = 600 Ω , gain = 40dB	0.015	%
Slew rate, RL = 150 Ω	18	V/ μs
Slew rate, RL = 75 Ω	16	V/ μs
Large-signal bandwidth, RL = 150 Ω	145	kHz
Small-signal bandwidth, at unity gain (ft)	10	MHz
Gain-bandwidth product, 10kHz to 100kHz	>50	MHz
Phase margin at 10MHz	>38	deg
Phase margin at <2MHz	>60	deg
Response time at unity gain	<20	nS
Supply current with no load	25	mA

990 Discrete Op-Amp

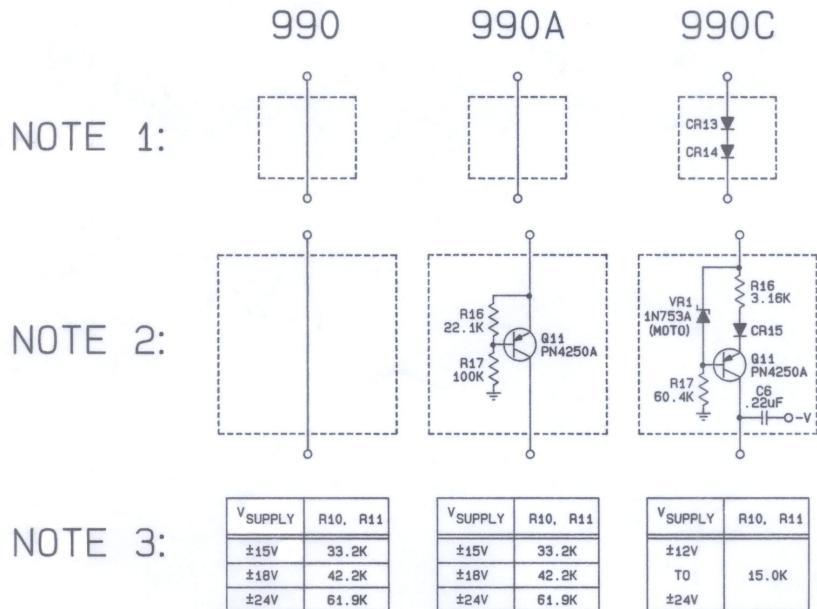
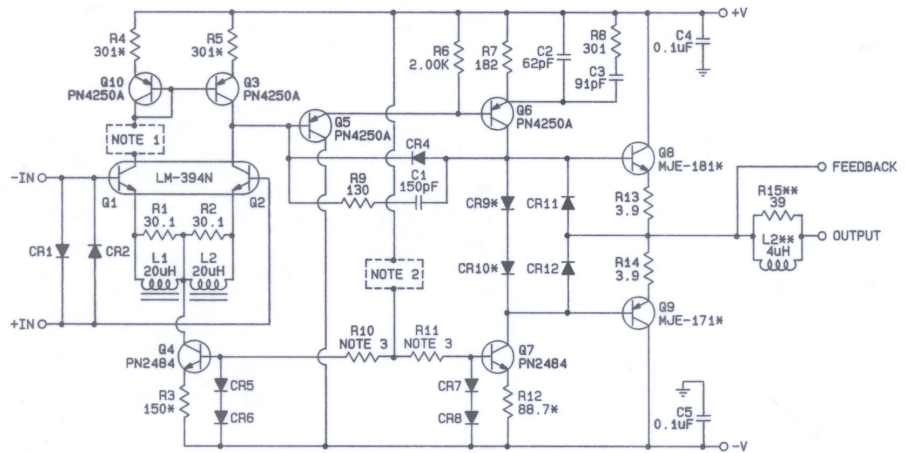

ALL DIODES 1N914B OR 1N4448.

* INDICATES A SELECTED OR TRIMMED PART.

** NOT INCLUDED IN THE 990 MODULES AS MANUFACTURED BY THE HARDY CO.

Application Notes

Following are several circuits for use with the 990 discrete op-amp. With proper attention to detail, you should achieve excellent results.

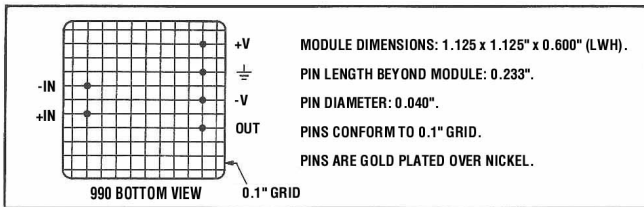
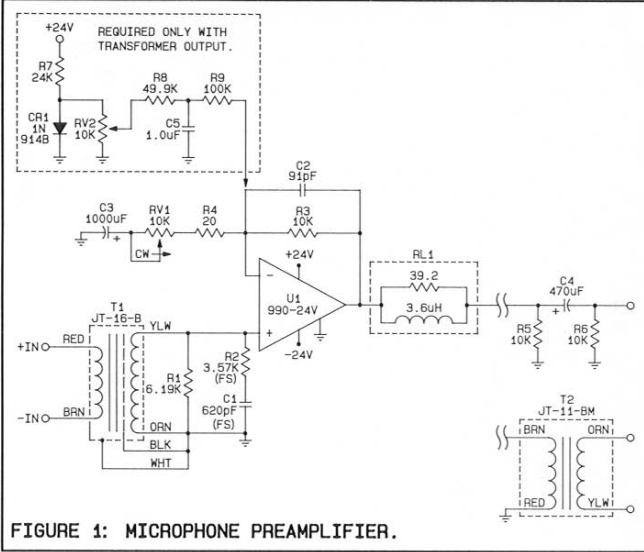

Figure 1: Traditional mic preamp. Figure 1 shows a traditional transformer-input mic preamp, adjustable from 11.6 to 60dB of gain including the input transformer step-up of 5.6dB. The circuit has a bandwidth of 150kHz (-3dB). The Jensen JT-16-B (or JT-16-A) mic-input transformer was designed specifically for the 990.



R1, R2 and C1 provide proper termination for the JT-16-B input transformer. R3, R4 and RV1 determine the AC voltage gain of the 990.

C3 is used for two reasons. First, it keeps the input bias current (thus DC voltage) of the inverting input of the 990 from reaching the gain-adjust pot (RV1) where it could cause noise during adjustment of the pot. All op-amps have small amounts of bias current flowing at their inputs. Small DC voltages develop as these currents flow through whatever DC resistance path is available ($E=I \times R$). Noise could occur during adjustment of the gain pot if more than about 1mV were to develop.

C3 also keeps the DC gain of the 990 at unity so that a small difference between the DC voltages at the inverting and non-inverting inputs of the 990 will not be amplified into a large offset voltage at the output.

An optional offset compensation circuit is shown. The diode regulator and filter circuit supplies a current to the inverting input which compensates for the unequal DC resistances seen at the inputs. The offset voltage at each input is found by multiplying the input bias current (typically 2.2μA) by the DC resistance seen at that input. For the non-inverting input, the DC resistance is the input transformer secondary resistance in parallel with R1 (6.19kΩ). For the inverting input R3 is the only DC path. Since the closed loop DC gain of the amplifier is unity, the DC offset at the output is equal to the difference of the offset voltages at the two inputs. The compensating current required into the inverting input is the offset voltage divided by R3 (10kΩ). This compensation will significantly reduce the DC offset at the output for applications with no output coupling capacitor.

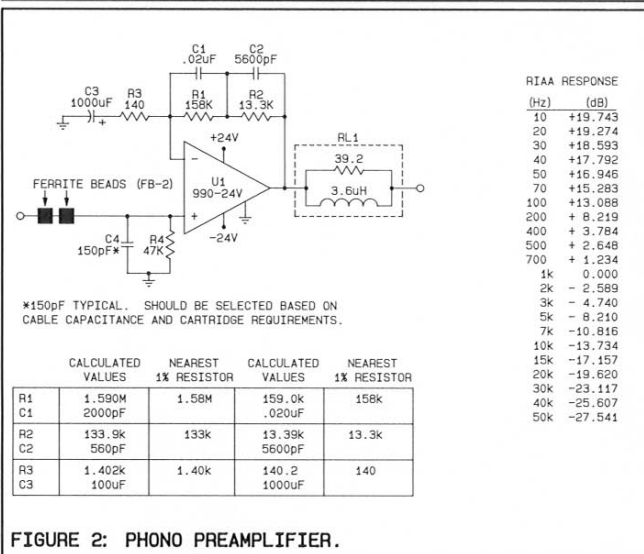

C2 provides phase-lead compensation with a high-frequency cut-off of 175kHz. C4 AC-couples the output of the 990 to remove any DC offset from the output.

The use of capacitors C3 and C4 to control various DC problems is traditional. For a superior approach that eliminates these capacitors and the sonic problems they can cause, see the application note for the M-1 mic preamp on page 7.

Figure 2: Phono preamp. Figure 2 shows a phono preamp with related component values and theoretical RIAA response figures. Gain is 41.7dB at 1kHz. The circuit provides RIAA response accuracy of ±0.1dB. The values are taken from a paper by Lipshitz [1] which covers RIAA equalization networks and their proper design.

Column 1 shows the exact calculated resistor and capacitor values. The nearest 1% resistor values are in column 2. Columns 3 and 4 show the values scaled by a factor of 10 to take advantage of the 990's lower noise figure at lower source impedances.

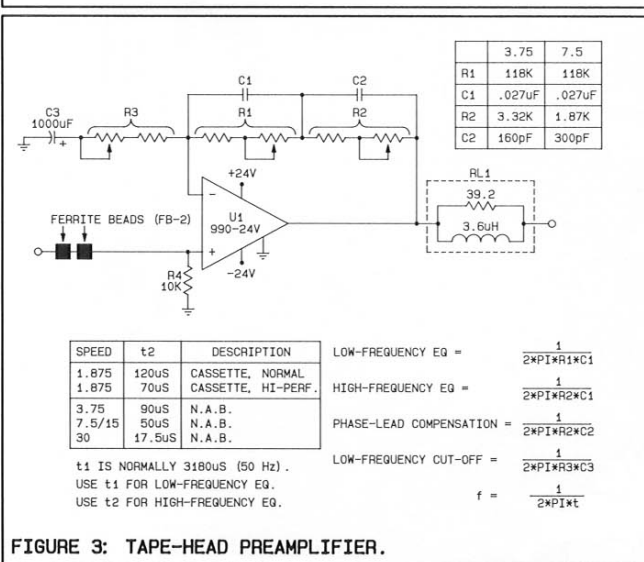

C3 AC-couples the 990, causing DC gain to be unity. C3 could be eliminated if offset compensation were performed. See figure 1 for one method. See the M-1 mic preamp application note for superior methods. The ferrite beads at the input are optional to reduce RFI.

REFERENCE: 1. Lipshitz, S., "On RIAA Equalization Networks", Journal, Audio Engineering Society, Vol. 27, #6, 6/79, pp. 458-481.

Figure 3: Tape-head preamp. Figure 3 shows a tape-head preamp. Component values for 3.75 and 7.5 ips NAB equalization and a gain of 50dB at 1kHz are listed. Other gains and equalizations can be achieved using the formulas provided. Tape head specs and characteristics vary widely, so the values listed will probably require trimming. The results should be carefully examined.

Tape heads with extremely low output levels will require additional gain. A 2nd op-amp should be considered for that purpose. It should have flat response. Each op-amp should be set for equal gain at high frequencies (20kHz).

This circuit is similar to the phono preamp, except it is tunable. The R2-C2 network is at 300kHz performing phase-lead compensation rather than RIAA equalization. See Phono preamp for comments on C3 and ferrite beads.

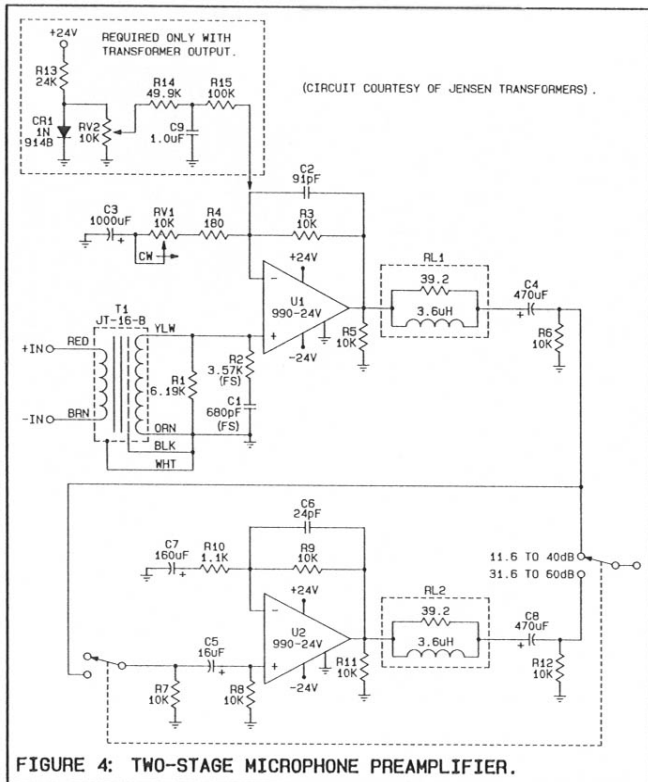

FIGURE 4: TWO-STAGE MICROPHONE PREAMPLIFIER.

Figure 4: Two-stage mic preamp. Figure 4 shows a two-stage transformer-coupled mic preamp, recommended for situations where extremely high gain is required. The first stage is the same as the single-stage preamp of figure 1 except the maximum gain is about 40dB. A switchable second stage with 20dB of gain gives a choice of single-stage operation with up to 40dB of gain (including the transformer step-up), or two-stage operation with up to 60dB of gain. The 2nd stage could be changed to adjustable gain. Ideally each stage would have the same amount of gain.

Offset voltage compensation can be performed on the first stage as described in the single-stage preamp text, or as shown in the M-1 application note. The second stage will have a low offset voltage because the inverting and non-inverting inputs see identical DC resistances (10kΩ). The techniques in the M-1 application note can be applied here too. See the data package for the Jensen Twin Servo® 990 Mic Preamp, a superior two-stage mic preamp using the JT-16-B input transformer and 990C op-amp. It eliminates all coupling capacitors by using DC servo circuitry and input bias current compensation circuitry.

Figure 5: Sockets. Many types of sockets for 0.040" D pins are available from several manufacturers. The John Hardy Co. uses and stocks the socket shown in figure 5, reprinted from the Concord catalog. The same part is also available from Cambion, a very similar part (but with less retention force) from Mill-Max. It can be soldered in place, or swaged (tool required). Here are three sources:

CONCORD ELECTRONICS INC.
30 Great Jones St.
New York, NY 10012

212-777-6571 800-847-4162
Part #09-9035-2-03

WEARNES CAMBION, LTD.
United Kingdom

011 44 1433 621555
800-947-1256 (USA & Canada)
Part #450-3756-02-03

MILL-MAX
190 Pine Hollow Road
Oyster Bay, NY 11771

516-922-6000
Part #0344-2-19-15-34-27-10-0

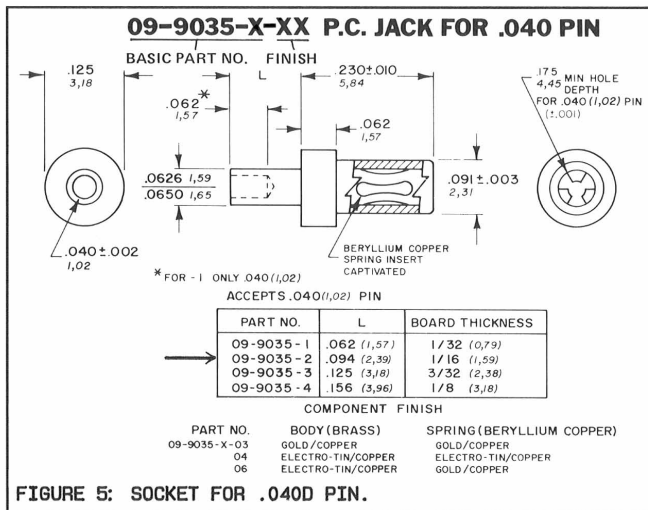

FIGURE 5: SOCKET FOR .040D PIN.

Figure 6: Summing amp. Figure 6 show a summing amp with several optional features. Some applications require signals to be combined at unity gain, others require different gains. For example, the signal from channel 3 is attenuated by a potentiometer (typically 10dB of attenuation) before it enters the summing circuit. To restore the 10dB lost through the pot, a lower value is used for R_{IN}, in this case 3.16kΩ (see formulas). With many channels being summed, the output of the summing amp could become excessive. The final value for R_{IN} is chosen based on the number of channels, signal levels, pot settings, etc.

The non-inverting input may be grounded directly, or through a resistor. The value of the resistor should equal the DC source resistance seen by the inverting input, which is the parallel resistance of all the input resistors (assuming they are not AC-coupled) and the feedback resistor (R_{IN} and R_{FB}). When both inputs of the 990 see identical DC source resistances, the output offset voltage will be the lowest. This resistor can result in increased noise when compared to a grounded input. This problem can be overcome by adding a capacitor in parallel with this resistor. The capacitor has infinite impedance at DC, so the DC specs are unchanged. The impedance is much lower above DC, so the noise performance of the 990 is not significantly compromised. The value of the capacitor is not critical, with 0.1μF being a good starting point. If the non-inverting input is grounded a compensation current can be provided to the inverting input as shown in the M-1 application note. This provides the lowest DC offset at the output of the 990, the lowest noise, and without the potential degradation caused by the capacitor.

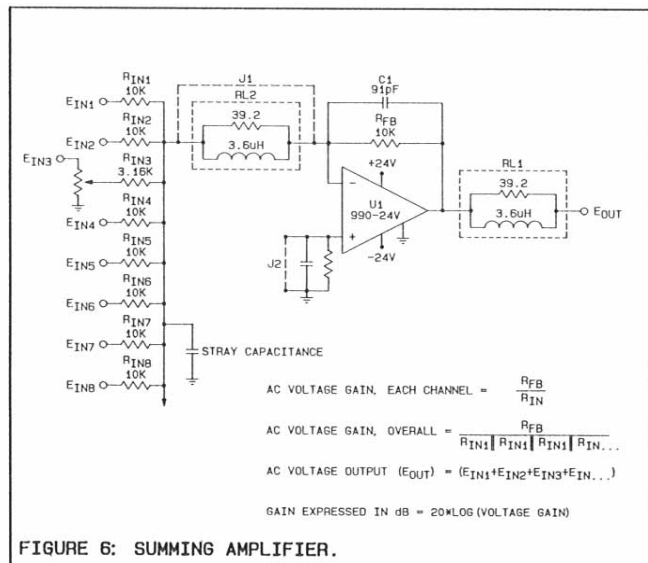
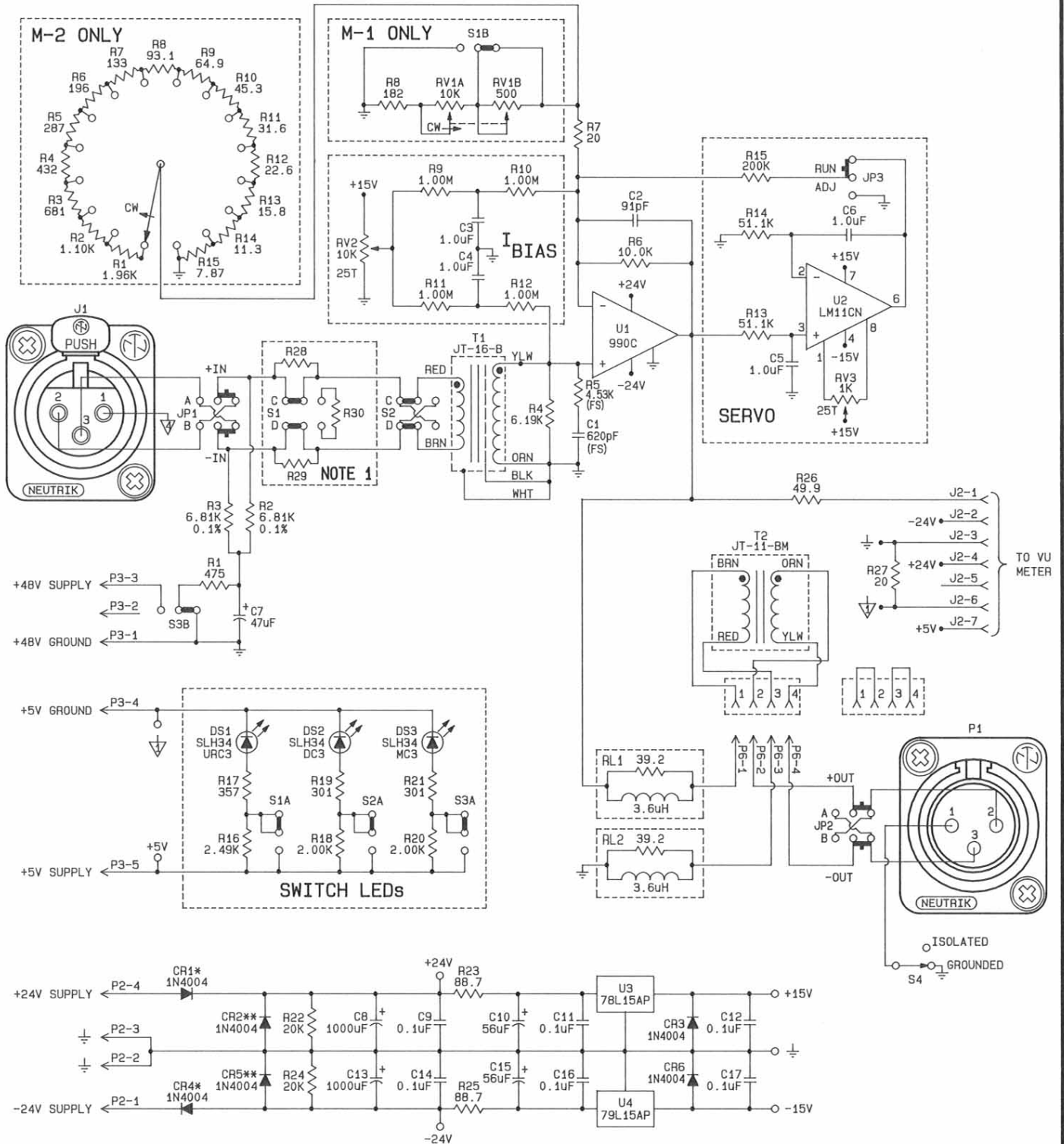

FIGURE 6: SUMMING AMPLIFIER.

The actual terminating point for the non-inverting input is critical! In large consoles with many inputs, much noise can appear on the ground bus. Even a heavy ground bus will have a measurable resistance, with voltage appearing across the resistance. These voltages can be in the form of power supply noise, return currents (thus voltages) from other modules, etc. Although each input of the summing amp may be at unity gain, the overall gain of the summing amp is higher. The greater the number of inputs, the higher the overall gain will be. For example, 24 inputs with R_N of 10kΩ results in a final parallel resistance of 417Ω, for a voltage gain of 24 (27.6dB) (see the formulas). That is how much the ground bus noise would be amplified if the non-inverting input were terminated far from the signal sources being summed. The 990 is much quieter than most other op-amps, but poor layout or grounding can defeat this advantage!

Long summing busses cause increased stray capacitance at the inverting input, resulting in phase-shift of the feedback signal. In sufficient quantities, this can cause oscillation at ultra-high frequencies. Capacitance can be added in the feedback loop to compensate. An isolator (RL2) can be inserted between the summing bus and the inverting input. It maintains normal audio performance by providing less than 1Ω impedance throughout the audio bandwidth, while isolating stray capacitance by providing 39.2Ω impedance at ultra-high frequencies.

MPC-1



PUSHBUTTON SWITCHES SHOWN IN UP POSITION.

VALUES FOR R5 AND C1 ARE TYPICAL. FINAL VALUES ARE FACTORY SELECTED (FS).

*THESE DIODES USED ONLY FOR CUSTOM APPLICATIONS. REPLACE WITH JUMPERS FOR M-1 USE.

**THESE DIODES USED ONLY FOR CUSTOM APPLICATIONS. DELETE FOR M-1 USE.

NOTE 1: FOR M-2 USE ONLY:
 20 OHM MIC: R28=68.1 R29=68.1 R30=OPEN.
 20dB PAD: R28=619 R29=619 R30=169.
 M-1: R28=JUMPER R29=JUMPER R30=OPEN.
 M-1: POLES 'C' AND 'D' OF S1 ARE NOT INSTALLED.



THE JOHN HARDY COMPANY

1728 BRUMMEL ST.
 P.O. BOX AA631
 EVANSTON, IL 60204
 (847) 864-8060

DRAWING #96102501D

M-1 Mic Preamp with Input Bias Current Compensation and DC Servo Circuitry

Figure 7 shows the complete circuit of the MPC-1 mic preamp card used in the M-1 and M-2 mic preamps, state-of-the-art mic preamps manufactured by the John Hardy Co. This circuit eliminates all coupling capacitors traditionally used in mic preamp circuits, and the degradation in signal quality that they can cause. The main difference between the M-1 and the M-2 is the type of gain control: a 2-section potentiometer in the M-1, a 16-position rotary switch in the M-2. See the M-1 and M-2 data package for further details.

At first glance capacitors seem like ideal components to use when trying to eliminate the DC voltages that always manage to creep into audio circuits. Capacitors have essentially infinite impedance at DC, and zero ohms impedance throughout the audio bandwidth if the value is large enough for the application.

However, capacitors also have problems. See the special report about ceramic capacitors on page 8 for a discussion of one problem. Another problem is dielectric absorption. This is a condition where a small portion of the AC voltage that passes through the capacitor is temporarily absorbed by the dielectric of the capacitor, then released a short time later, causing a smearing of the sound. The severity of the problem depends on the type of dielectric in the capacitor, and other construction details.

The problem tends to be unmeasurable with normal test methods, but can be audible. Some film dielectrics such as polypropylene, polycarbonate, polystyrene and Teflon minimize the problem. But when a circuit requires several hundred microfarads, it is out of the question to use them, both from a space and cost standpoint. A compromise approach has been to use electrolytic capacitors of the required large value, then add a 1.0 μ F or 0.1 μ F (or both) film capacitor in parallel, the theory being that low frequencies will be handled by the large electrolytic capacitor, and high frequencies (where the smearing would be most audible) will be handled by the small film capacitors.

Traditional transformer-input mic preamps typically have two coupling capacitors in the signal path. Referring to the traditional mic preamp circuit of figure 1 they are C3 and C4. Their functions are discussed in that application note.

Mic preamps with transformerless inputs have two additional coupling capacitors to keep the +48V phantom power supply voltage from reaching the active circuitry of the preamp where it would cause damage. An input transformer inherently blocks DC voltages, but does not suffer from the problem of dielectric absorption that capacitors have. Manufacturers of transformerless mic preamps might say that these capacitors cause less sonic damage than an input transformer. This is true of some input transformers, but not with the Jensen JT-16-B input transformer used in the M-1! This is Jensen's finest input transformer, and it is truly superior. See the M-1 data package for details.

The M-1 takes a different approach. Rather than forcing the audio signal to pass through

various capacitors to block the DC voltages (and, in the process, smear the audio signal), the DC voltages are nulled using special circuitry. The coupling capacitors are completely eliminated.

The input bias current compensation circuit ("I_{BIAS}") on the MPC-1 mic preamp card provides an adjustable current to each input of the 990 op-amp. The current is the opposite polarity of the normal input bias currents of the 990 op-amp. When RV2 is properly adjusted, the input bias currents of the 990 are nulled so that no DC voltages are developed at the inputs of the 990. Traditionally a coupling capacitor (C3 in Figure 1) is used in series with the gain controls to keep DC voltages from reaching the gain controls where they could cause noise during adjustment of the control. The I_{BIAS} circuit eliminates the need for this DC-blocking capacitor.

Since all input-related DC voltages have been nulled by the I_{BIAS} circuit, it is no longer necessary to worry about a small difference in the voltages at the inputs being amplified into a large DC error or offset at the output of the 990. Therefore it is not necessary to limit the DC gain of the 990 to unity, a function that C3 also traditionally performs. Again, C3 can be eliminated by using the I_{BIAS} circuitry.

A +15V reference voltage is applied to the top of RV3, a 25-turn trim pot. The trimmed voltage is applied to the inputs of the 990 as a current through R9, R10, R11 and R12. C3 and C4 act as noise filters.

The DC servo ("SERVO") circuit continuously monitors the output of the 990 for the presence of any DC offset, and provides a correction to the inverting input of the 990 through R15. The final DC offset of the 990 is determined by the DC offset characteristics of the servo op-amp (U2). The AD705J was chosen because it has exceptional DC characteristics, with a typical DC offset of 200 microvolts and drift of 2 microvolts/°C. The DC offset performance of the AD705J is further improved by an order of magnitude through the use of trim pot RV3. (Currently the OP97FP is used as the DC servo op-amp. The LT1012 and LM11CN op-amps were used in earlier production).

The servo circuit itself acts as an ultra-low frequency low-pass filter. The F_{-3dB} frequency is so low (well below 1Hz) that essentially only DC is passed through the circuit and applied to the inverting input of the 990 as a nulling signal. The two R/C networks, R13/C5 and R14/C6, along with R15, determine the operating frequency. The capacitors have no detrimental effect on the audio signal because they only affect frequencies in the pass-band of the filter (well below 1Hz).

Input Bias Current Calibration

Whenever a 990 op-amp is replaced, it should be assumed that it has a different input bias current than the previous 990. The input bias current adjustment procedure

should be performed as follows:

1. Install the new 990, turn on the power and allow the unit to warm-up for at least 15 minutes.
2. Connect a DC voltmeter with at least 100 microvolt sensitivity to the circuit as follows: The Positive lead connects to test point #1 ("TP1"). This is the output of the 990 op-amp. A long gold pin is provided for TP1, located along the left edge of the p.c. board near the rear. The negative lead connects to ground. A long gold pin is provided for this ground connection to the rear of the 990 op-amp.
3. Move JP3 to the ADJUST ("ADJ") position. JP3 is located to the right of the 990 op-amp. This disconnects the DC servo circuit so you can measure the DC offset of the 990 op-amp.
4. Set the gain controls to minimum gain and make note of the DC offset measured at TP1.
5. Set the gain controls to maximum gain and adjust RV2 so that the DC offset reading is within 1 millivolt of the reading taken when the gain controls were at minimum gain. It may take several seconds for this measurement to settle. RV2 is a 25-turn trim pot labeled I_{BIAS} located to the right of the 990 op-amp.
6. Repeat steps 4 and 5 until the DC offset measurements are within 1 millivolt of each other at minimum and maximum gain. Note that both readings may be several millivolts, or even tens of millivolts. They might both be positive, or negative. The important thing is that they are within 1 millivolt of each other, and the same polarity.
7. Move JP3 to the "RUN" position. This reconnects the DC servo. This should cause the DC offset voltage of the 990 op-amp to drop to well below 1 millivolt. In fact, the DC offset should drop to well below 100 microvolts if the DC servo circuit is functioning properly.

DC Offset Calibration

The final DC offset of the MPC-1 mic preamp card is determined by the performance of the DC servo op-amp (U2). An AD705J or OP97 op-amp is used because it has excellent DC specifications. It is capable of providing a DC offset that is typically less than 200 microvolts without any additional trimming. This is excellent, but can be improved by an order of magnitude through the use of trim pot RV3.

When making DC measurements below 100 microvolts you will need a DC voltmeter with a sensitivity and resolution of at least 1 microvolt. Most meters will have DC offsets of their own to deal with, as well as drift due to time and/or temperature. Even the cables and test probes can introduce errors. Follow the meter instructions very carefully regarding warm-up time and zeroing procedures.

When you have properly warmed-up and zeroed your meter, adjust RV3 until the DC offset measurement between TP1 and ground is as close to ZERO microvolts as possible.

Ceramic Capacitors

Ceramic capacitors have a bad reputation in audio circles. It is only partially deserved. Many engineers are unaware that there are several distinctly different grades of ceramic capacitors, each having a unique formulation of ceramic dielectric, and a unique set of properties. The three most common E.I.A. [1] types are:

1. Ultra-stable: COG dielectric (also called NPO [2]).
2. Stable: X7R dielectric.
3. General purpose: Z5U dielectric.

The COG dielectric is a vastly superior performer. It is also more expensive, particularly in values above a few hundred pF, and is usually dismissed as cost-prohibitive. A common mistake is to shop by price alone and buy the cheaper dielectrics, not realizing the serious performance compromises. The engineer then condemns all ceramics based on the limited experience with only the inferior types. Too Bad! Examination of the performance graphs of figure 1 reveals significant differences between the dielectrics. In each case – capacitance vs. temperature, capacitance vs. time (aging), capacitance vs. applied AC voltage, capacitance vs. DC stress, and dissipation vs. temperature – the X7R and Z5U dielectrics show significant compromises when compared to the COG formulation.

The X7R and Z5U formulations trade off electrical performance for increased volumetric efficiency. To achieve this a ferroelectric material is used. Ferroelectric behavior is complex. An excellent text by Centre Engineering [3] provides a comprehensive discussion of this and other ceramic properties. Essentially, ferroelectricity causes capacitance to change as the applied voltage to the capacitor is changed. In audio applications the AC voltage passing through a ferroelectric dielectric would modulate the capacitance. In resistor/capacitor networks in equalizers and crossovers this modulation causes distortion which increases as the signal frequency approaches the cut-off frequency of the R/C network.

Tests were conducted with the COG, X7R and Y5V ceramic dielectrics (Y5V is similar to the Z5U formulation) to measure total harmonic distortion vs. frequency when used as high-pass and low-pass filters. Figure 2 shows the specific HP and LP filter circuits and the test results. The X7R and Y5V formulations show significant amounts of distortion, but the COG formulation, being non-ferroelectric, shows distortion figures at or very near the residual of the measuring equipment.

An article by Jung and Marsh [4] presented the same test, but with the X7R dielectric only, providing a negative view of ceramic capacitors. The balance of the article is very enlightening, as it enters into relatively unexplored areas of capacitors in audio applications. A more recent paper by Jung [5] makes the distinction between the various ceramic dielectrics and expresses a favorable view of the COG/NPO dielectric.

The COG ceramics were chosen for use in the signal path of the 990 op-amp as manufactured by the John Hardy Company for several reasons. First, their performance is exceptional, as noted. Second, though the higher values are usually considered cost-prohibitive, the low values used in the 990 (62pF, 91pF and 150pF) are cost-competitive with other dielectric types. Third, they are the smallest capacitors available, extremely important when 47 components must be packaged on a 1" square p.c. board.

Hopefully this information will provide a better understanding of ceramic capacitors. Each formulation has its proper place, and for audio applications, the COG dielectric is superior.

References:

1. E.I.A. = Electronic Industries Association.
2. NPO = Negative-Positive-Zero, indicating a temperature coefficient of capacitance that is neither plus nor minus, but is very close to zero. Tempco = ± 30 ppm, -55 to +125°C.
3. "TECHNICAL INFORMATION, Ceramic Capacitors." Capacitor catalog, Centre Engineering, 2820 E. College Ave., State College, PA 16801
4. Jung, W., Marsh, R., "Picking Capacitors - Part 1" Audio, 2/80; "Picking Capacitors - Part 2" Audio, 3/80
5. Jung, Walter G., "Topology Considerations for RIAA Phono Preamplifiers". A.E.S. preprint #1719(D1).

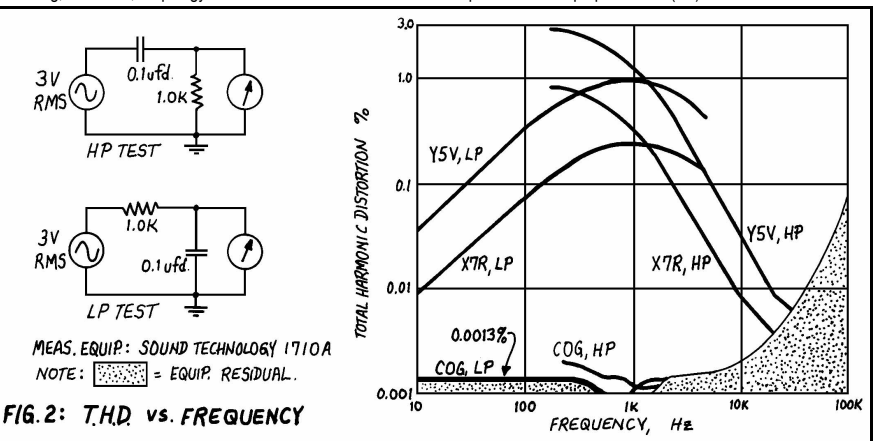
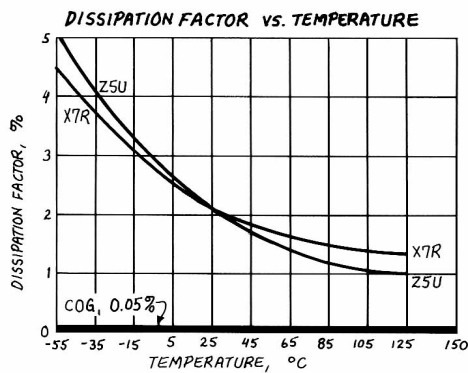
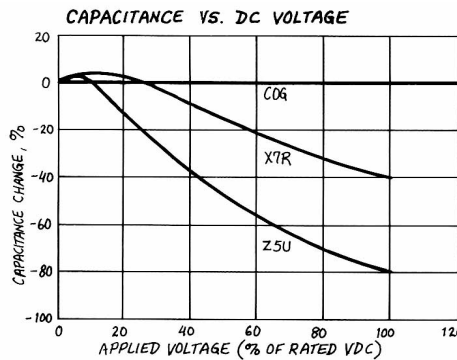
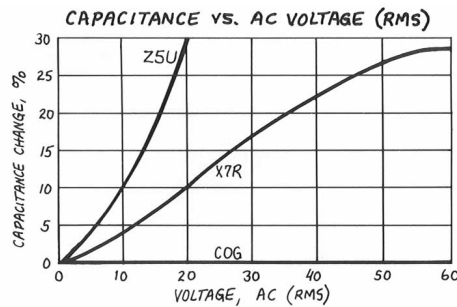
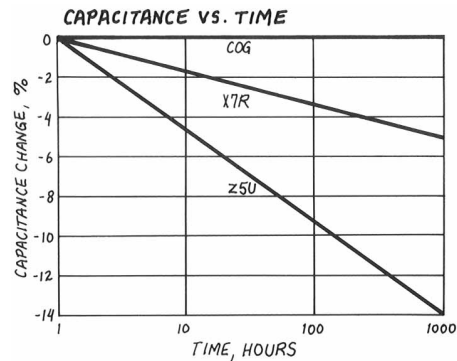
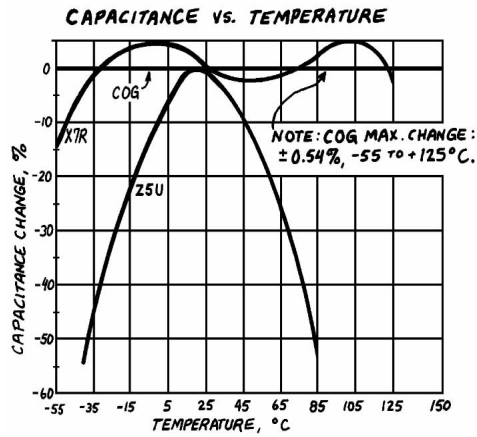

FIG. 2: T.H.D. vs. FREQUENCY