

CONDITIONING TECHNIQUES FOR REAL-WORLD SENSORS

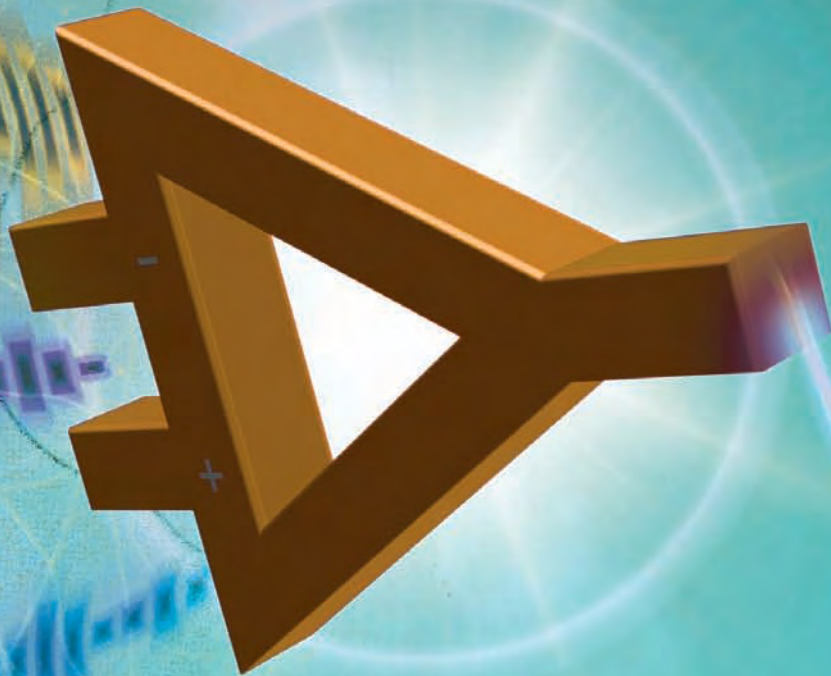

BY STEVE TARANOVICH

SENIOR TECHNICAL EDITOR

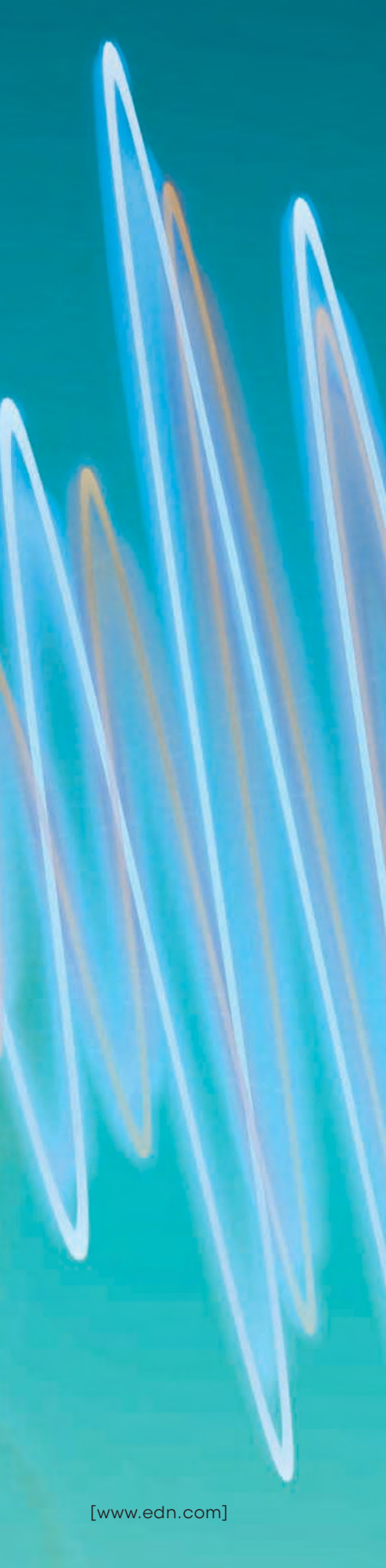

**MANY REAL-WORLD SENSORS
PRODUCE LOW OUTPUT VOLTAGES
AT LOW FREQUENCIES THAT REQUIRE
A SIGNAL-CONDITIONING CIRCUIT
WITH HIGH GAIN AND ACCURATE—
CLOSE TO DC—PERFORMANCE.
WE ASSESS THE STATE OF THE ART IN
SENSOR SIGNAL CONDITIONING FOR
MODERN ANALOG ELECTRONICS.**

Modern sensors detect a multitude of real-world analog attributes—temperature, force, pressure, humidity, flow, and power, just for starters. In turn, they typically output some level of voltage, current, charge, or resistive analog signal, or a purely digital signal, in proportion to their respective environmental stimuli. Some sensors operate autonomously; others need power supplied, typically in the form of a voltage or current source. Many times, unique signal conditioning is needed or incorporated to provide a useful electrical output. Here, we look at some state-of-the-art techniques for sensor signal conditioning used in modern analog electronics.

As the need for highly precise operational amplifiers continues to grow, the self-correcting architectures—designs that continuously correct for offset error—have become increasingly popular. Many leading amplifier manufacturers use “zero drift” to refer to any continuously self-correcting architecture, whether it is an auto-zero or a chopper-stabilized topology, observes Kevin Tretter, principal product marketing engineer at Microchip Technology Inc. Typically, chopper amplifiers are better suited for dc or low-frequency applications, whereas auto-zero amplifiers are suitable for wider-band applications.

Tretter notes that auto-zero architectures used for zero-drift signal conditioning contain a main amplifier, which is always connected to the input, and secondary amps that continuously correct their own offset and apply the offset correction to the main amplifier. Microchip Technology has implemented this type of architecture on the MCP6V01, in which the offset error of the main amplifier is corrected 10,000 times/sec, resulting in what Microchip says are extremely low offset and offset drift.

A chopper-stabilized architecture also uses a high-bandwidth main amplifier that is always connected to the input, as well as an “auxiliary” amplifier that uses switches to chop the input signal and provide offset correction to the main amplifier. In Microchip’s MCP6V11 low-power amplifier, for example, chopping action minimizes offset and offset-related errors.

Although their internal operation differs, auto-zero and chopper-stabilized amplifiers share the same goal: to minimize offset and offset-related errors. This results in not only low initial offset but also low offset drift over time and temperature, superior common-mode and power-supply rejection, and elimination of $1/f$ (frequency-dependent) noise.

CHOPPER ARCHITECTURES

Reza Moghimi, an applications engineering manager with Analog Devices Inc, notes that many real-world sensors produce low output voltages at low frequencies that require a signal-conditioning circuit with high gain and accurate—close to dc—performance. Applications for such sensors include precision electronic scales, load-cell and bridge transducers, interfaces for

AT A GLANCE

- Typically, chopper amplifiers are better suited for dc or low-frequency applications, whereas auto-zero amplifiers are suitable for wider-band applications.
- Two very common topologies respectively construct instrumentation amplifiers from two and three op amps.
- Energy harvesting powers a microprocessor or transmitter from a remote location without a local power source.
- Complete solutions need to address sensor drive and output requirements, sample rate, signal-path calibration, performance, sensor diagnostics, and power-consumption needs.
- Wireless sensor networks are changing the way information is gathered, increasing the amount and accessibility of data about the physical world.

thermocouple/thermopile sensors, and precision medical instrumentation.

The offset voltage, offset-voltage drift, and $1/f$ noise of nonprecision amplifiers used for signal conditioning of these sensors cause errors that require hardware or software calibration. Moghimi offers examples of high-precision signal conditioning in which zero-drift amplifiers—designed to achieve ultralow offset voltage and drift, high open-loop gain, high power-supply rejection, high common-mode rejection, and no $1/f$ noise—benefit designers by eliminating the need for calibration.

The circuit in **Figure 1** uses the AD7791, a low-power buffered 24-bit sigma-delta ADC, along with external ADA4528-x zero-drift amplifiers, in a single-supply precision weigh-scale application. The circuit, built and tested by ADI and described in **Reference 1**, yields 15.3-bit noise-free code resolution for a load cell with a full-scale output of 10 mV and maintains good performance over the full output data range, from 9.5 Hz to 120 Hz.

The differential amplifier in the circuit comprises two low-noise, zero-drift ADA4528 amplifiers with $5.6 \text{ nV}/\sqrt{\text{Hz}}$ of voltage noise density at 1 kHz, 0.3-

μV offset voltage; $0.002 \text{ }\mu\text{V}/^\circ\text{C}$ offset-voltage drift; and 158 dB and 150 dB of common-mode and power-supply rejection, respectively. Circuit gain is equal to $1+2R_1/R_G$, and the lowpass filters implemented by placing capacitors C_1 and C_2 in parallel with resistors R_1 and R_2 limit the noise bandwidth to 4.3 Hz, restricting the amount of noise entering the sigma-delta ADC. C_5 , R_3 , and R_4 form a differential filter with a cutoff frequency of 8 Hz to limit noise further. C_3 and C_4 in conjunction with R_3 and R_4 form common-mode filters with a cutoff frequency of 159 Hz.

Another example of high-precision, low-power signal conditioning is the electrocardiogram circuit shown in **Figure 2** and described in **Reference 2**. The ECG circuit must operate with a differential dc offset because of the half-cell potential of the electrodes. The tolerance for this overvoltage is typically $\pm 300 \text{ mV}$, but in some situations it can be 1V or more. The downward trend of supply voltages in ECG circuits and the presence of this larger half-cell potential limit the gain that can be applied in the first stage of signal conditioning.

The AD8237 architecture solves this problem by connecting a low-frequency inverting integrator from the output to the REF pin that only has to swing as far as the dc offset, instead of the dc offset multiplied by the gain. Because the amplifier applies gain to the integrator output, large gains can be applied at the amplification stage, and the precision requirements of the rest of the system can be reduced. Noise and offset error from devices after this amplification in the signal path contribute less to the overall accuracy. The AD8607 dual micropower instrumentation amp, with 115 μA of supply current, is used for integration, buffering, and level shifting. Proper decoupling is not shown.

The zero-drift, rail-to-rail input and output instrumentation amplifier can operate with a minimum supply voltage of 1.8V, gain drift of 0.5 ppm/ $^\circ\text{C}$, and offset drift of 0.2 $\mu\text{V}/^\circ\text{C}$. Two external resistors set gain range from 1 to 1000. The AD8607 can fully amplify signals with common-mode voltage at or up to 300 mV beyond its supplies.

APPLICATIONS

Microchip’s Tretter notes that when chopper-stabilized amplifiers first came

Figure 3 A Wheatstone-bridge sensor conditioned by a zero-drift op amp is shown. Even when using multiple sensors in a Wheatstone-bridge configuration, the total change in output voltage is relatively small; thus, a gain stage is usually required before converting the voltage to a digital signal via an ADC (courtesy Microchip Technology).

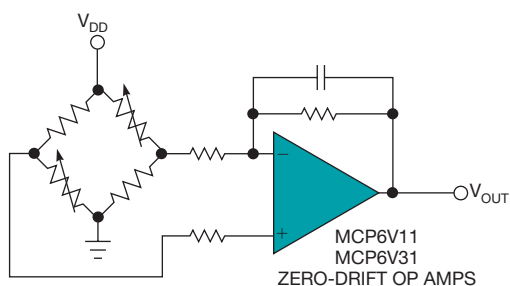

to market, their large switching current and layout sensitivity made them difficult to use as well as cost prohibitive. Designers thus limited implementation to select applications in which performance was absolutely critical. Advances in process technology and silicon design have since enhanced the usability of zero-drift amplifiers, proliferating their use across a wide range of applications, including medical devices; industrial flow meters, multimeters, and high-end weight scales; and even gaming devices.

Many sensors, such as strain gauges, RTDs (resistance temperature detectors), and pressure sensors, are commonly arranged in a Wheatstone-bridge configuration (**Figure 3**) because that circuit type offers excellent sensitivity. Even when using multiple sensors in a Wheatstone-bridge configuration, the total change in output voltage is relatively small, typically in the millivolt range. Because of the small signal amplitude, a

gain stage is usually required before converting the voltage to a digital signal via an ADC. Zero-drift amplifiers are a good choice for such applications because of the need for high gain and minimum noise, Tretter says.

IA DESIGN CONSIDERATIONS

Adolfo A Garcia, vice president of marketing and applications for Touchstone Semiconductor, notes that when supply voltages are low (<3V) and the available choices for self-contained IAs (instrumentation amplifiers) are limited, designing your own IA is straightforward, so long as the op amp's input and output dc characteristics and circuit topologies are understood. Two very common topologies respectively use two and three op amps to construct the instrumentation amp.

Figure 4 shows the two-op-amp topology. When applying single-supply, rail-to-rail, low-power op amps, primary considerations for their selection,

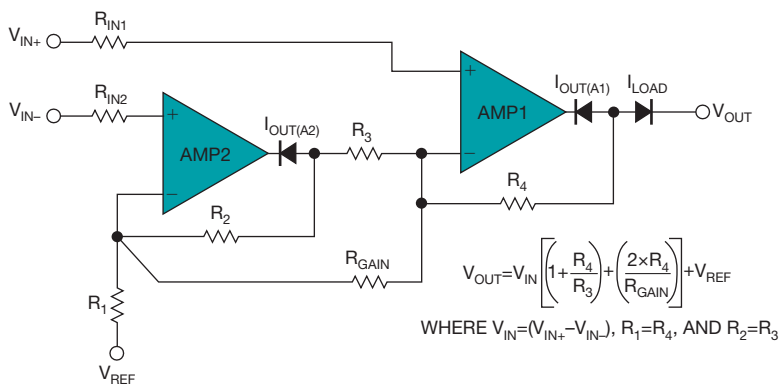

Figure 4 This illustration of a conventional two-op-amp instrumentation amp and its associated output/input voltage-transfer equation shows that two single-supply op amps can be configured into an instrumentation amplifier if certain op-amp parameters are understood and applied correctly (courtesy Touchstone Semiconductor).

WIRELESS SENSOR NETWORKS WRING MORE UTILITY FROM REAL-WORLD DATA

Wireless sensor networks are changing the way information is gathered, increasing the amount and accessibility of data about the physical world. The cost of deploying a wired sensor network is often 10 to 100 times the cost of the sensor. According to Joy Weiss, president of the Dust Networks Product Group at Linear Technology Corp, the real value of WSNs is that you can put a sensor anywhere—not just where power or communications wires are already conveniently located, but wherever you want to take a measurement or add a control point to a system.

Weiss cites some examples of applications enabled by WSNs:

- Vigilent provides intelligent energy management systems, based on its M3 closed-loop control technology, for data centers, telcos, and large commercial buildings.

To collect the necessary temperature and humidity data throughout the data center, sensors need to be widely and densely distributed. Retrofitting the data center with communications and power cabling, however, is impractical and cost prohibitive. Vigilent uses wireless connected sensor nodes to address those concerns. In selecting Linear Technology's Dust Networks SmartMesh solution for its product, Vigilent identified as critical success factors the need for low power consumption, high reliability, and robust security.

- Emerson Process Management helps businesses automate their production, processing, and distri-

bution in the chemical, oil and gas, refining, pulp and paper, power, water and wastewater treatment, metals and mining, food and beverage, life sciences, and other industries. Emerson's Smart Wireless products and solutions, based on the IEC 62591 wireless standard and incorporating Linear/Dust's SmartMesh WirelessHART products, extend predictive intelligence into areas previously beyond physical or economic reach.

- Streetline provides smart-parking solutions to cities, garages, airports, universities, and other parking providers (Figure A) and aims to make smart cities a reality through the use of sensor-enabled mobile and Web applications. Streetline needed a wireless networking solution robust enough to function in harsh and dynamic street conditions—one that could be large and dense and that could run for years without a battery change.



Figure A Streetline Networks' smart-parking management solution uses Linear Technology/Dust Networks' wireless technology in a wireless mesh network overlaid on urban streets. Wireless sensors buried in the pavement gather information on parking-space availability that is sent wirelessly to smartphone users.

Streetline's smart-parking solution uses Linear/Dust's SmartMesh technology in a wireless mesh network overlaid on streets in the Hollywood/Los Angeles area. Wireless sensors buried in the street pavement track parking-space availability; the information is then sent wirelessly to smartphone users.

depending on the application, include dc parameters such as V_{OS} , TCV_{OS} , $A_{VOL(MIN)}$, I_{OS} , $V_{OH(MIN)}$, and $V_{OL(MAX)}$, and ac parameters such as the amplifier input-referred noise and bandwidth. Regardless of the application, maximizing output dynamic range is key to achieving maximum circuit performance. Single-supply op amps whose output stages offer the widest dynamic range are the best choices, according to Garcia, because amplifier output-stage saturation is to be avoided.

Note the reference-voltage term (V_{REF}) in the circuit's transfer equation in **Figure 4**. To avoid output saturation in AMP1, the instrumentation amp's output signal must be measured relative to V_{REF} . In a 3V (or lower) system, one might conclude that, in order for the circuit to exhibit maximum dynamic range and avoid output-stage saturation, simply setting V_{REF} equal to one-half the supply is sufficient. That conclusion is only valid, however, if the selected op amp's $V_{OH(MIN)}$ and $V_{OL(MAX)}$ specifications are symmetric with respect to its supply datum, Garcia observes.

Dispensing with a rigorous nodal circuit analysis of the two-op-amp IA topology involving the differential input signal voltage (V_{IN}), the applied input common-mode voltage (V_{CM}), and the reference voltage, V_{REF} should be designed so as to bias AMP1's output in the middle of its output voltage swing (and not exactly at one-half the supply voltage), as **Equation 1** shows:

$$V_{REF} = \frac{V_{OH(MIN)} + V_{OL(MAX)}}{2}. \quad (1)$$

Select the desired gain of the IA so as to prevent output-stage saturation. In the case of the two-op-amp IA, the expression derived from the nodal circuit analysis is shown in **Equation 2**:

$$\text{Circuit gain} = \frac{V_{OH(MIN)} + V_{OL(MAX)}}{2 \times V_{IN(MAX)}}. \quad (2)$$

In **Equation 2**, $V_{IN(MAX)}$ is the maximum differential input voltage applied to the IA circuit. If the desired gain is a known circuit parameter, you can rearrange the appropriate terms in the equation to determine the maximum input differential voltage that can be applied to the circuit to prevent output-stage saturation.

For the lowest power operation,

ANALOG DATA SHEETS



For a collection of data sheets on the latest analog products, go to www.datasheets.com.

resistors used in the circuit should be 100 k Ω or larger, depending on noise and bandwidth design considerations. Also, it is important to point out that an op amp's $V_{OH(MIN)}$ and $V_{OL(MAX)}$ voltage specifications are highly dependent on amplifier output-stage loading, so pay particular attention to load-resistor conditions.

In a real-world example, a TS1002 dual 0.6- μ A op amp was chosen to construct a gain-of-10 two-op-amp IA that operates from a 2.5V supply. The TS1002's $V_{OH(MIN)}$ and $V_{OL(MAX)}$ specifications into a 100-k Ω load are 2.498V and 0.001V, respectively. Using **Equation 1**, a V_{REF} equal to $(2.498V+0.001V)/2=1.249V$ offsets the output stage to maximize output dynamic range and avoid output-stage saturation. At a prescribed gain of 10, the maximum differential input voltage that can be applied to avoid output-stage saturation is $(2.498V+0.001V)/(2\times 10)$, or 125 mV.

You can perform a similar analysis on the three-op-amp IA configuration (**Figure 5**). Again, dispensing with the rigor of a comprehensive nodal circuit analysis of the three-op-amp IA and involving the terms mentioned previously, the results of the two-op-amp IA apply equally well here; that is, for maximum dynamic range, the output reference voltage is set to be in the middle of AMP1 and AMP2's output-voltage swing (**Equation 1**).

The expression for circuit gain is of the same form as for the two-op-amp IA (**Equation 2**). The circuit's output voltage is measured with respect to V_{REF} ; V_{REF} is designed to be in the middle of AMP1 and AMP2's output-voltage swing; and the maximum differential input voltage that can be applied to the three-op-amp IA is determined from **Equation 2**.

In another real-world example, designers used a Touchstone Semi TS1004 0.6- μ A quad op amp to construct a gain-of-50 three-op-amp IA that operates from a 2.5V supply. From the TS1004's data sheet, its $V_{OH(MIN)}$

and $V_{OL(MAX)}$ specifications into a 100-k Ω load are 2.498V and 0.001V, respectively. Using **Equation 1**, the output stage is offset by a V_{REF} equal to $(2.498V+0.001V)/2=1.249V$ in order to maximize output dynamic range and avoid output-stage saturation. At a prescribed gain of 50, the maximum differential input voltage that can be applied to avoid output-stage saturation is $(2.498V+0.001V)/(2 \times 50)$, or 25 mV.

ENERGY HARVESTING

Tony Armstrong, director of product marketing for power products at Linear Technology Corp, describes powering remote wireless nodes via renewable energy sources that can be harvested efficiently, given the right harvesting, power-management, and battery-charging devices (see **sidebar**, “Wireless sensor networks wring more utility from real-world data”). Renewable energy is providing expanded opportunities for energy conversion and more effective use of existing energy, but it also provides an opportunity for energy-

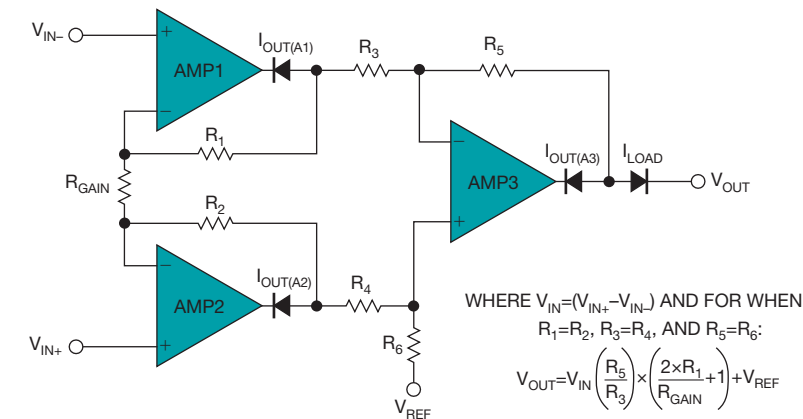

Figure 5 Three single-supply op amps can be configured into an instrumentation amplifier if certain op-amp parameters are understood and applied correctly (courtesy Touchstone Semiconductor).

harvesting devices to help power wireless sensor networks, commonly used in building-automation and predictive-maintenance applications.

Armstrong notes that the conventional approach for energy harvesting has been through solar panels and wind

generators, but emerging energy-harvesting tools enable the generation of electrical energy from a variety of ambient sources. For instance, thermoelectric generators convert heat to electricity, piezo elements convert mechanical vibration, photovoltaics convert sun-

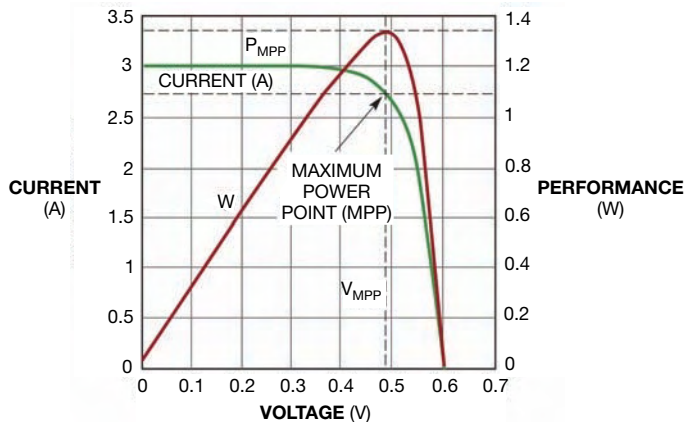

Figure 6 The typical maximum-power-point control point for a single photovoltaic cell is shown. Maximum power output for a given light intensity occurs at the knee of each curve, where the cell transitions from a constant-voltage device to a constant-current device (courtesy Linear Technology).

light (or any photon source), and galvanics convert energy from moisture. This makes it possible to power remote sensors, or to charge a storage device such as a capacitor or thin-film battery, enabling a microprocessor or transmitter to be powered from a remote loca-

tion without a local power source.

Linear's energy-harvesting products provide enabling solutions (**Table 1**). Specs vary across the line, but the company touts quiescent currents typically less than 6 μA and as low as 450 nA; start-up voltages down to

20 mV; input-voltage capability up to 34V continuous, 40V transient; the ability to handle ac inputs; multiple-output capability and autonomous system power management; autopolarity operation; maximum-power-point control for solar inputs; the ability to harvest energy from as little as a 1°C temperature delta; and compact solution footprints.

Because solar power is variable, nearly all solar-powered devices feature rechargeable batteries. Clearly, the goal is to extract as much solar power as possible to charge these batteries quickly and to maintain their state of charge.

While solar cells are inherently inefficient devices, they do have a point of maximum output power, so operating at this point is an obvious design goal. The problem, Armstrong observes, is that the IV characteristic of maximum output power changes with illumination. A monocrystalline solar cell's output current is proportional to light intensity, whereas its voltage at maximum power output is relatively constant. Maximum

power output for a given light intensity occurs at the knee of each curve, where the cell transitions from a constant-voltage device to a constant-current device (Figure 6).

Therefore, a charger design that

efficiently extracts power from a solar panel must be able to steer the panel's output voltage to the point of maximum power when illumination levels cannot meet the charger's full power requirements. Linear's LT3652 mul-

tichemistry 2A battery charger for solar-power applications uses an input-voltage regulation loop that reduces the charge current if the input voltage falls below a programmed level set by a simple voltage-divider network. When

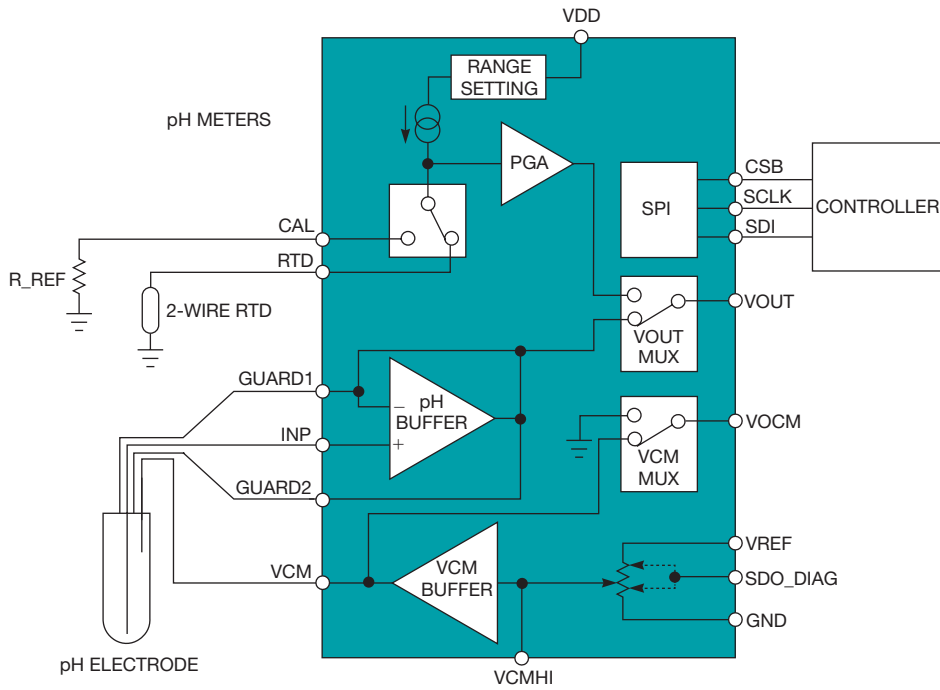

Figure 7 The LMP91200 configurable AFE delivers an integrated pH-sensor AFE circuit that interfaces with all available pH sensors and bridges the gap between sensor and microprocessor (courtesy Texas Instruments).

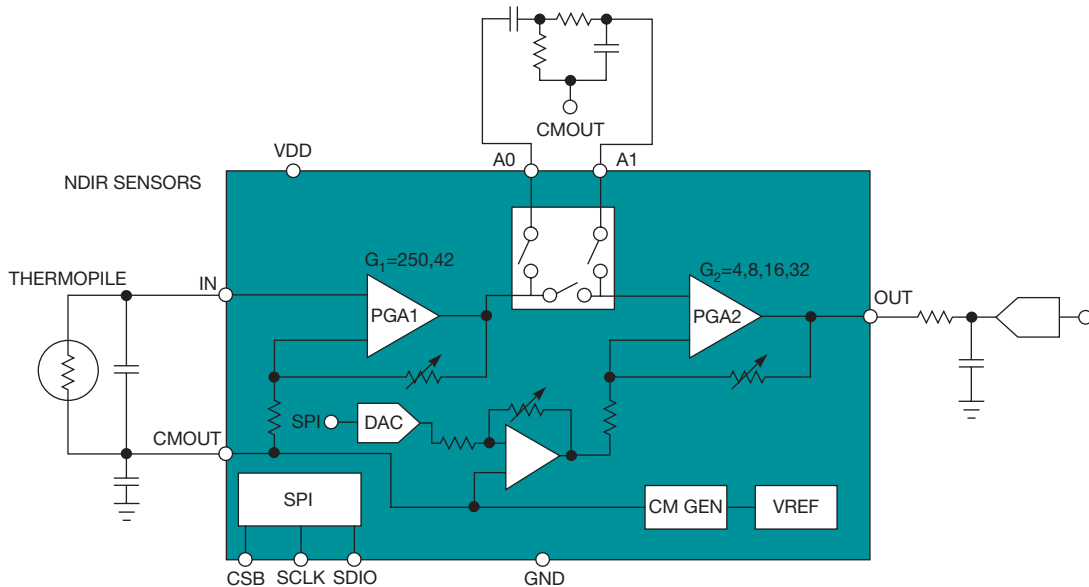

Figure 8 The LMP91050 NDIR gas-sensing AFE supports multiple types of thermopile sensors (courtesy Texas Instruments).

TABLE 1 LINEAR TECHNOLOGY INTEGRATED CIRCUITS FOR RENEWABLE-ENERGY APPS

Part number	Description	Energy source
LTC3108	20-mV thermal-energy harvester	Thermal differential
LTC3109	Autopolarity thermal-energy harvester	Thermal differential
LTC3588	Piezo energy harvester	Vibration/strain; piezoelectric
LTC3105	250-mV step-up dc/dc converter with MPPC	Solar photovoltaic
LT3652(HV)	Power-tracking 2A battery charger for solar power	Solar photovoltaic
LTC4070/71	Li-ion shunt battery-charger systems	Solar; piezoelectric

powered by a solar panel, the input-voltage regulation loop maintains the panel at near peak output.

INTEGRATED AFE APPROACH

Complete sensor solutions need to address sensor drive and output requirements, sample rate, signal-path calibration, performance, sensor diagnostics, and power-consumption needs. Simplifying the cycle and reducing development time can mean a faster time to market and more designs completed per year. Most existing approaches, however, address only a few of those issues and are time-consuming and complicated to develop with discrete components.

Texas Instruments' configurable sensor AFE (analog front-end) ICs and Webench Sensor AFE Designer are part of an integrated hardware and software development platform that lets an engineer select a sensor, design and configure the solution, and download the configuration in minutes. Engineers can evaluate the complete signal-path solution online or on the bench.

Achieving accurate pH measurements in industries such as food processing, water-quality management, and chemical processing involves dealing with design challenges that include extreme temperature variations, high output impedances, offsets, and drifts. TI says its LMP91200 configurable AFE delivers an integrated pH-sensor AFE circuit that interfaces with all available pH sensors and bridges the gap between sensor and micro-processor (Figure 7), addressing the

design challenges in an integrated, small form factor.

TI's LMP91050 NDIR (nondispersive infrared) gas-sensing AFE, meanwhile, supports multiple thermopile sensors for NDIR sensing, indoor-air-quality monitoring, demand-controlled ventilation, HVAC, alcohol-intake breath analysis, greenhouse-gas monitoring, and Freon detection (Figure 8).EDN

REFERENCES

- 1 Analog Devices, Circuit Note CN0216, "Precision Weigh Scale Design Using the AD7791 24-Bit

Sigma-Delta ADC with External ADA4528-1 Zero-Drift Amplifiers," pg 1, <http://bit.ly/PVccQB>.

2 Analog Devices, AD8237 data sheet, "Micropower, Zero Drift, True Rail-to-Rail Instrumentation Amplifier," pg 26, <http://bit.ly/WOOVBY>.

You can reach Senior Technical Editor Steve Taranovich at 1-632-413-1834 and steve.taranovich@ubm.com.



Microcontroller Development Tools

STREAMING TRACE
MICROCONTROLLER
EMBEDDED DEVELOPMENT TOOLS
TCP/IP NETWORKING SUITE
ULINKPRO
GUI LIBRARY

CORTEX
USB HOST
CMSIS
CAN DRIVER
DEBUGGING
USB DEVICE

MDK-ARM
FLASH FILE SYSTEM
EVALUATION BOARDS
ENERGY EFFICIENCY
MIDDLEWARE LIBRARIES
ARM COMPILER
RTOS

The complete development environment for ARM® processor-based microcontroller designs.

1-800-348-8051
www.arm.com/tools

AD319 | 02.12

JOIN THE CONVERSATION

To comment on this article, go to www.edn.com/4400585.