

Undervoltage protection with comparator circuit

Design Goals

Battery Voltage Levels (V_{BAT})		Comparator Output Status (OUT)	
Undervoltage (V_{LOW})	Start-Up Operating Voltage (V_{HIGH})	Low Battery	Normal Operation
< 2.000V	> 2.034V	$V_{OL} < 0.4V$	$V_{OH} = V_{PU} = 1.8V$

Design Description

This undervoltage, protection circuit uses one comparator with a precision, integrated reference to create an alert signal at the comparator output (OUT) if the battery voltage sags below 2.0 V. The undervoltage alert in this implementation is ACTIVE LOW. So when the battery voltage drops below 2.0 V, the comparator output goes low, providing as an alert signal to whatever device is monitoring the output. Hysteresis is integrated in the comparator such that the comparator output will return to a logic high state when the battery voltage rises above 2.034 V. This circuit utilizes an open-drain output comparator in order to level shift the output high logic level for controlling a digital logic input pin. For applications needing to drive the gate of a MOSFET switch, a comparator with a push-pull output is preferred.

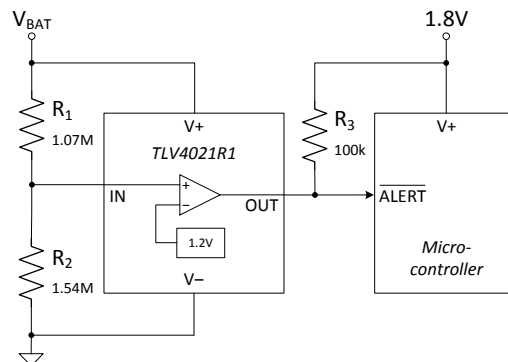

Design Notes

1. Select a comparator with a precision, integrated reference.
2. Select a comparator with an open-drain output stage for level-shifting.
3. Select values for the resistor divider so the critical undervoltage level occurs when the input to the comparator (IN) reaches the comparator's negative-going input threshold voltage (V_{IT}).

Design Steps

1. Calculate the resistor divider ratio needed so the input to the comparator crosses V_{IT-} when V_{BAT} sags to the target undervoltage level (V_{LOW}) of 2.0V. V_{IT-} from the TLV4021R1 data sheet is 1.18V.

$$V_{IT-} = \frac{R_2}{(R_1 + R_2)} \times V_{LOW}$$

$$\frac{R_2}{(R_1 + R_2)} = \frac{V_{IT-}}{V_{LOW}} = \frac{1.18 \text{ V}}{2.00 \text{ V}} = 0.59$$

2. Confirm that the value of V_{LOW} , the voltage level where the undervoltage alert signal is asserted, is 2.0 V.

$$V_{LOW} = \frac{R_1 + R_2}{R_2} \times V_{IT-} = \frac{1}{0.59} \times 1.18 \text{ V} = 2.0 \text{ V}$$

3. Select values for R_1 and R_2 that yield the resistor divider ratio of 0.59 by using the following equation or using the online tool "Voltage Divider Calculator" at http://www.ti.com/download/kbase/volt/volt_div3.htm.

If using the following equation, choose a value for R_2 in the Mega-ohm range and calculate for R_1 . In this example, a value of 1.54 M was chosen for R_2 .

$$R_1 = R_2 \left(\frac{V_{LOW}}{V_{IT-}} - 1 \right) = 1.54 \text{ M}\Omega \left(\frac{2 \text{ V}}{1.18 \text{ V}} - 1 \right) = 1.07 \text{ M}\Omega$$

4. Verify that the current through the resistor divider is at least 100 times higher than the input bias current of the comparator. The resistors can have high values to minimize power consumption in the circuit without adding significant error to the resistor divider.
5. Calculate V_{HIGH} , the battery voltage where the undervoltage alert signal is de-asserted (returns to a logic high value). When the battery voltage reduces below the 2.0-V level or is ramping up at initial start-up, the comparator input needs to exceed (V_{IT+}), the positive-going input threshold voltage for the output to return to a logic high. V_{IT+} from the TLV4021R1 data sheet is 1.20V.

$$V_{HIGH} = \frac{R_1 + R_2}{R_2} \times V_{IT+} = \frac{1.07 \text{ M}\Omega + 1.54 \text{ M}\Omega}{1.54 \text{ M}\Omega} \times 1.20 \text{ V} = 2.034 \text{ V}$$

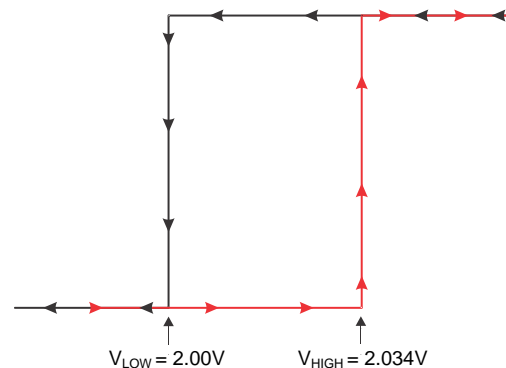

Design Simulations

DC Simulation Results

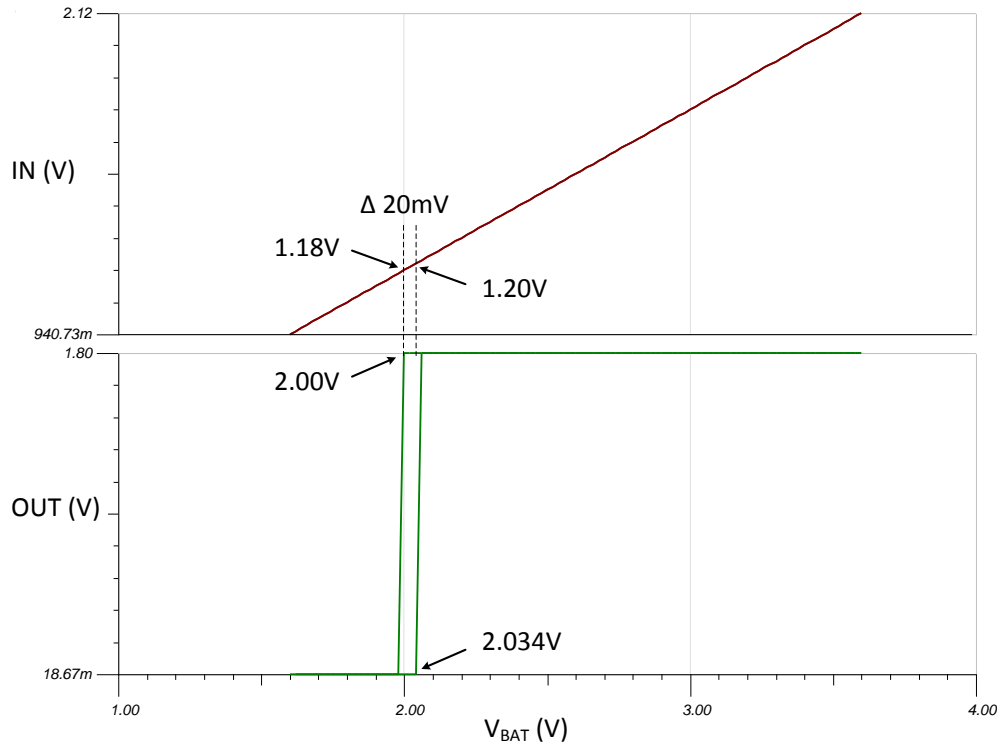

Transient Simulation Results

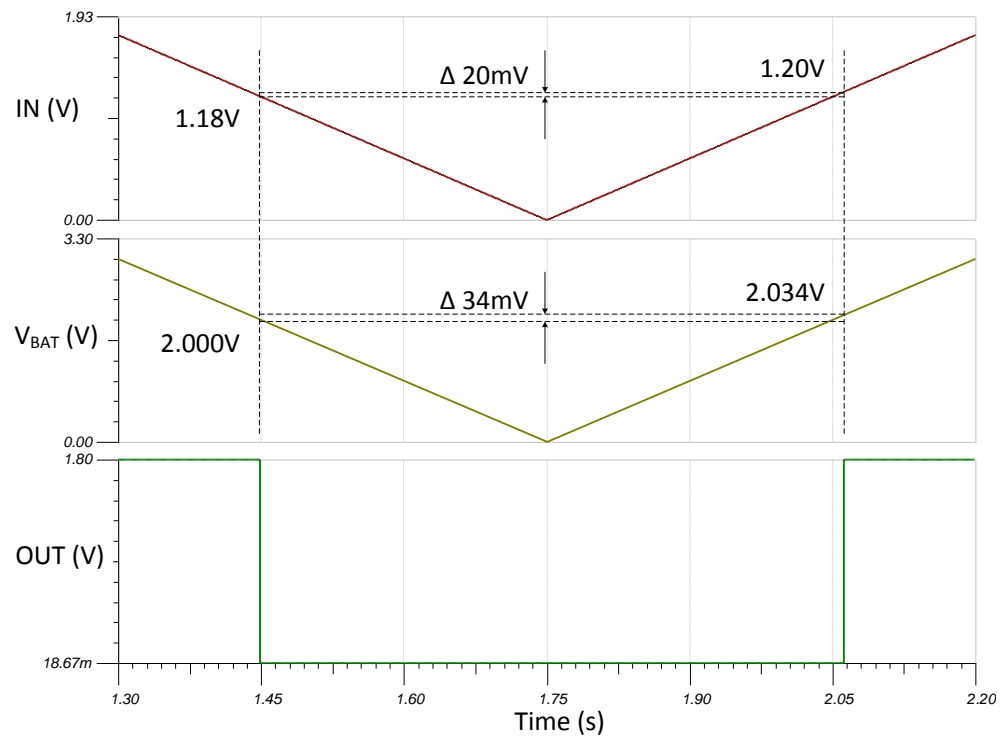

References:

1. [Analog Engineer's Circuit Cookbooks](#)
2. SPICE Simulation File – [SNOAA18](#)
3. [TI Precision Labs](#)

Design Featured Comparator

TLV4021R1	
V_S	1.6V to 5.5V
V_{inCM}	Rail-to-rail
V_{OUT}	Open Drain
Integrated Reference	1.2V \pm 1% over temperature
Hysteresis	20 mV
I_Q	2.5 μ A
$t_{PD(HL)}$	450 ns
www.ti.com/product/tlv4021	

Design Alternate Comparator

	TLV4041R1	TLV3011
V_S	1.6V to 5.5V	1.8V to 5.5V
V_{inCM}	Rail-to-rail	Rail-to-rail
V_{OUT}	Push-Pull	Open Drain
Integrated Reference	1.2 V \pm 1% over temperature	1.242 \pm 1% room temperature
Hysteresis	20mV	NA
I_Q	2.5 μ A	2.8 μ A
$t_{PD(HL)}$	450ns	6 μ s
	www.ti.com/product/tlv4041	www.ti.com/product/tlv3011