

Car Alarm

Protect your car and its contents with this cheap and simple alarm

By Bob Noyes

The number of car thefts increases daily and the old adage 'lock it' is a little outdated as car thieves seem to be able to open, steal from or even drive away just about any car they choose.

In order to protect what is probably the second largest investment the average family makes, some further protection is required.

Auto theft, as the police call it, takes two forms — breaking into a car to steal from it (commonly for items such as cassette decks etc) and the actual theft of the car. Some protection against both is necessary.

Although at first glance, these requirements seem simple enough, other practical factors need to be considered which complicate the issue — for instance how to switch it on and off. Drilling holes in the outside bodywork of the car is out of the question because this tends to introduce rust round the switch. It will also get splattered with mud and spray from passing vehicles making the switch inoperative after a time.

Magnetic key fobs and infra red controllers, at first glance look like a possible way of actuating and deactuating from outside the car, but in practice needs to be used in one position around the car and this is not always easy when parked in awkward places. Both systems add to the time taken by the driver to gain access to the car, something not appreciated in the rain.

The only practical way is a delayed exit and entry but this can introduce a period when a would-be car radio thief

has broken in and started hacking away at the wiring of the radio before the alarm sounds. Although the radio is unlikely to be removed in this time, a great deal of damage can be done.

The alarm described here is of the delayed entry and exit type but has the added advantage that when the alarm has been tripped by opening the door or trunk an internal buzzer sounds. This, although not very loud, indicates that an alarm has been set off and something else is about to happen. This should be enough to deter a thief as the last thing he wants is to be seen around a car with an alarm sounding.

Another important factor in an alarm is what form the output takes. Most commercial alarms sound their horns and lights intermittently. This, although very effective, doesn't do much for the horn, lights or battery as these draw an enormous amount of power and are usually controlled by a relay whose contacts arc and spark when switching these currents.

The contacts can weld themselves together sounding the horn and the lights continuously until the battery is flat. The alarm timer which all alarms must have cannot cancel a welded relay! As well as the possible damage because of the high currents, thick and bulky hard to handle wires need to be used. For safety, the alarm switch should switch off all power to the alarm and the supply to the lights and horns used when controlled by the alarm. This would mean a switch capable of 25A or so and not many

alarms on the market supply such switches.

To eliminate this problem the sound output is generated by rotary siren having a maximum current consumption of 1.2A. This allows the whole installation to be fused at 2A so much thinner wires can be used.

As a secondary line of defence, the car can be immobilized when the alarm is switched on. One of two methods can be used. If the car is fitted with standard mechanical points, a capacitor can be switched in across them. The value should be in excess of 22u but with a working voltage of 600V or more. This is switched into circuit by an independent set of contacts on the alarm switch.

In most modern cars an optical or magnetic sensing system is used in place of the points. In these cases it is best to leave well alone as damage can be caused by connecting a capacitor in the wrong place so a switch is placed into the 12V supply side of the electronic ignition module. This can be found using a meter or by following the cars' circuit diagram. Again it is wired back to the alarm key switch.

Operation

On leaving the car the alarm is activated by the key switch. This allows about seven seconds to get out and shut the door. After this time the alarm becomes active and is indicated by the exit delay LED extinguishing (it comes on when the alarm is switched on). The alarm is now active and opening the

Car Alarm

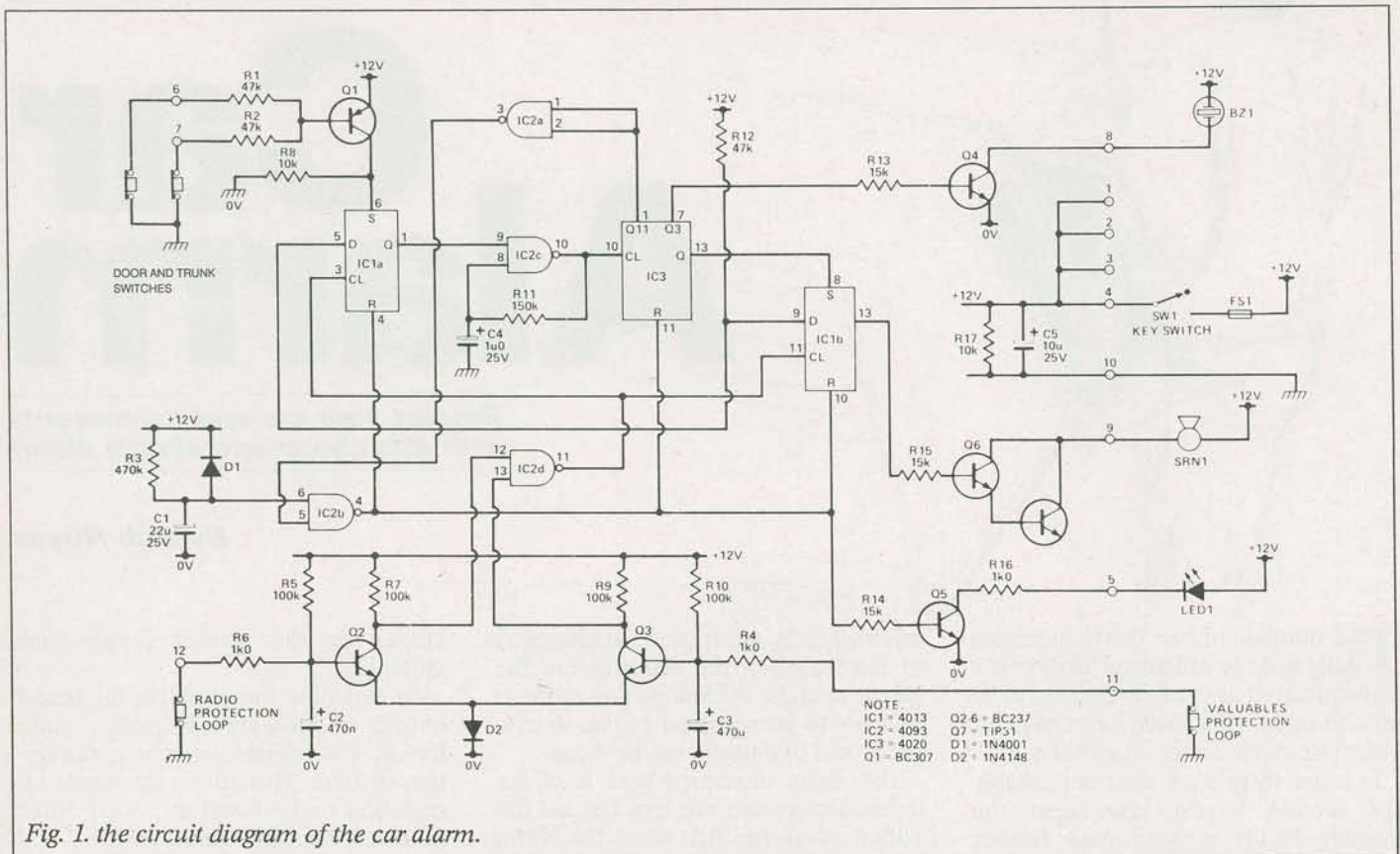

Fig. 1. the circuit diagram of the car alarm.

door will start the following sequence which once started cannot be stopped by shutting the door. Only the key switch will stop it.

The internal buzzer sounds eight times over about a five second period. During this time the alarm should be de-activated by the key switch. Failure to do this will sound the main siren. The siren sounds for approximately one and a half minutes. It will then shut off and reset the alarm. If the door is left open the sequence will start again and will not stop unless the key switch is turned off or the door is shut and then only at the end of the sequence.

If the radio or any other equipment is tampered with and the ground connection removed, the siren will sound immediately.

Instead of the radio, a trailer can also be protected when connected to a car and parked. A loop connection is made around the trailer frame. This can be made with a plug and socket arrangement in such a way that the plug must be removed or the wires cut in order to steal the trailer. In both cases, the alarm will sound instantly. Of course provision must be made to short the wires together when the trailer is not being towed. This can be achieved

with a shorting plug kept in the socket when not protecting the trailer.

The same method can be used to protect such articles as cases and the like carried in the car. The set up must be that to remove the protected articles, the plug must be undone or the cable cut, similar to the type of thing used in shops to protect goods on view.

Although primarily intended for cars, this alarm is ideal for RV trailers as the

CMOS integrated circuits draw very little current and can be left on for several months without flattening the battery. The delayed circuit can be fitted to the main doors. The instant circuit can be connected to the wind up leg of the RV so that with the leg down the contacts are made (use a mercury tilt switch). When the leg is wound up to drive the RV away the tilt switch

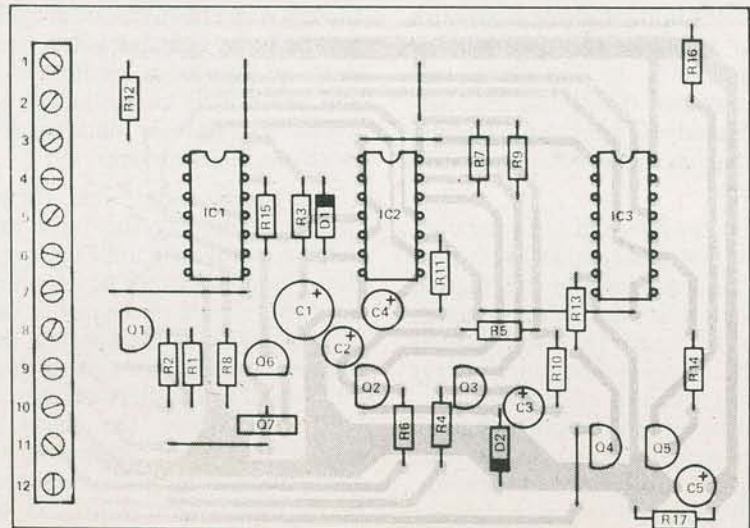
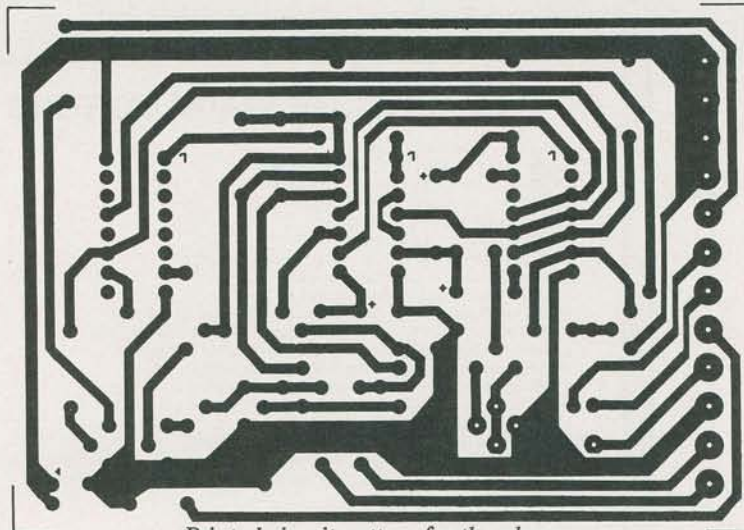

Fig. 2 The component overlay of the alarm PCB.



Printed circuit pattern for the alarm.

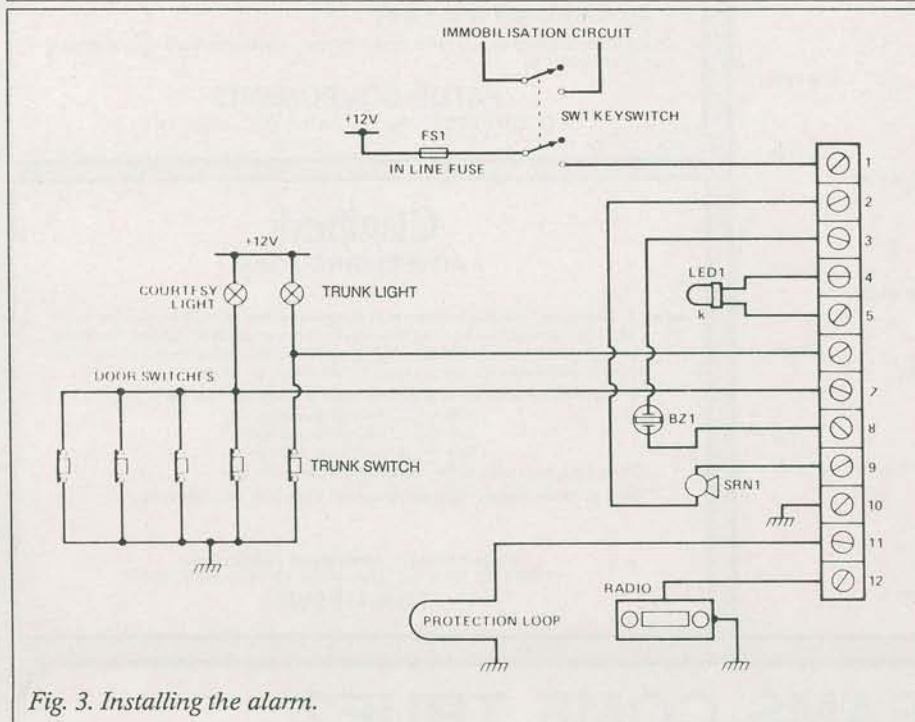

Fig. 3. Installing the alarm.

contacts open and set off the alarm immediately.

How It Works

Fig. 1 shows the full circuit diagram of the alarm. When the alarm is on and the exit delay timed out, opening any one of the doors or trunk will close the light switches and turn on Q1 via R2 or R1. This produces a high on IC1a and will set the latch causing the output to go high starting the oscillator (IC2c) which runs at about 25Hz. Pulses from this are fed to a binary counter IC3, the outputs of which control the following sequence of events. After eight pulses from the oscillator, Q3, goes high and

is high for eight more pulses before going low and repeats this throughout the sequence. The Q3 output is taken to Q4 via R13 to give current amplification and power a small buzzer. This is the internal buzzer which sounds eight times before the main siren. After 128 clock pulses, Q7 goes high and sets latch IC1b. This is the siren latch, and when set it causes the siren to sound via R15 supplying Q6, Q7 which are wired in a Darlington configuration.

After a total 2048 clock pulses, Q1 1 becomes high which is inverted by IC2a. The resulting low on IC2b causes a short reset pulse which resets IC1a,

Parts List

Resistors (all 1/4W, 5%)

R1,2,1247k
R3470k
R4,6,161k0
R5,7,9,10100k
R8,1710k
R11150k
R13-1515k

Capacitors

C122u 25V tantalum
C2,3470n 25V tantalum
C41u0 25V tantalum
C510u 25V tantalum

Semiconductors

IC14013
IC24093
IC34020
Q12N6015
Q2-52N5825
Q6TIP31
D11N4001
D21N4148
LED1Red Led

Miscellaneous

BZ112V Piezo Buzzer
FS12A inline fuse
SRN112V siren or bell
SW1DPDT Key Switch
PCB;	plastic case, connectors and cable; 12 way terminal strip; extra switches on doors and trunk if necessary; nuts and bolts.

IC3 and IC1b. The alarm has now gone through a complete sequence and is ready to be set off again should the need arise.

The delayed exit is produced by IC2b. After switch-on C1 is slowly charged via R3 while charging IC2 pin 4 is high. This turns on Q5 via R14 to illuminate the exit LED via its current limit resistor R16. When C1 has charged to about eight volts, this will cause pin 4 to fall to 0 volts, a high must appear on pin 5 due to the counter being rest causing a low on Q1 1 which is inverted by IC2a.

The delay exit time may be increased by increasing the value of R3. D1 provides a discharge path for C1 when the alarm is switched off. R17 provides the load for the discharge path.

The delayed entry is provided by the 128 clock pulses required to set the siren state during which time the alarm should be turned off. By this method of sequencing various time configurations may be achieved by simply selecting the outputs from IC3 to lengthen or shorten the timings. For example, taking the rest from Q1 1 (pin 1) to Q1 2 (pin 2) will double the length of time the siren sounds to nearly three minutes. *continued on page 54*

Car Alarm *continued from page 47*

If an attempt is made to remove the radio or other protected items, the siren sounds instantly. This is done by using the latches IC1a, IC1b. Pins 11 and 12 of the alarm are held low by connecting them to the chassis of the radio or connecting them to 0 volts via the loops described earlier. If one of these two connections is removed either Q2 or Q3 is turned on by their bias resistors R5, R9 respectively. This in turn puts a low on IC2d pins 12 or 13 which causes the output pin 11 to go high. This low to high transition is used to clock the two latches IC1a, b. The circuit now follows the same count routine as before except that the siren latch has already been set eliminating the 128 clock pulse delay, but it is turned off in the same way after 2048 clock pulses.

The timings rely on the oscillator running at about 25Hz. The speed of this oscillator can be increased by reducing R11 and slowed down by increasing its value. However, do not reduce below 15k as this may damage the IC.

Installation

Fig 2. shows the overlay for the alarm PCB. Construction should cause no particular problems.

Before fitting the alarm, it should be fully tested on the bench using a power supply and simple switches on pins 6, 7, 11, 12. To simulate the car courtesy light, connect a 47k resistor between pins 1 and 6 of the alarm. This will hold off Q1 unless turned on by a low on pins 6 or 7.

When happy that the alarm works under all possible valid switch configurations it should be considered ready to fit. As it is going to stay in the car (which can be a hostile environment) the PCB should be fully cleaned and sprayed with a PCB protective varnish to prevent the copper tracks from being eaten away by dampness.

Test all points of the car's electrical system that are to be used with a meter to check they perform as expected. It is a good idea to disconnect the positive side of the battery while fitting the alarm to prevent any accidental shorts. ■

Oops!

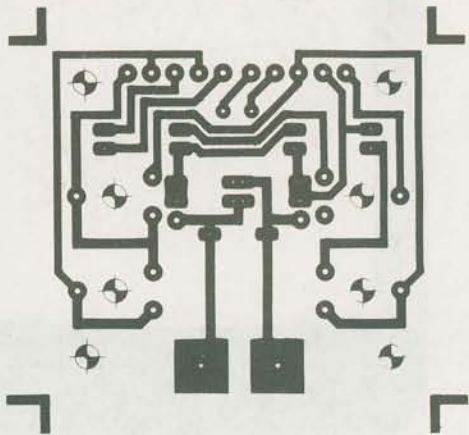

The PCB artwork for the Power Meter project in our February issue was supplied at 50% full size. The full size artwork is given above.

Oops, the second. In Fig. 1 of the Car Alarm project from the same issue, Q7 is not numbered and its emitter is shown unconnected. This should connect to ground. Also, the transistors in the parts list are numbered incorrectly. They should read Q2—6 2N5825 and Q7 is the TIP31.